

# Lab Manual

## PREFACE

This series of fiber optics laboratory experiments was developed by Professor Elias Awad for the FOA under a NSF grant. It is intended to prepare students in technical colleges and some high schools for the technology of fiber optics.

No previous experience in fiber optics is required. Students are expected to read all sections of each laboratory write-up before starting with the “procedure” section of each experiment. In some cases, the teacher may wish to use this laboratory manual as a text. We included in each experiment enough theory, tutorial material and examples to fulfill the needs of some programs.

Teachers may wish to hold the students responsible to do the exercises provided with the laboratory write-ups.

Teachers offering a full semester of fiber optics will find it necessary to have a regular textbook for the lecture section of the course. The FOA Textbook, *The Fiber Optic Technicians Manual*, is one choice, but at a college level, a text with more theory, such as *Fiber Optic Communications* by Jim Downing or Jeff Hecht's *Understanding Fiber Optics*

Several laboratory write-ups suggested that the students do the experiment with more than one type of fiber. If this requirement is not fulfilled due to the lack of resources, the educational benefit of the experiment will not be lost.

Elias A. Awad  
email: [photons@flash.net](mailto:photons@flash.net)

# Lab Exercise 1

## 1- TITLE:

Termination of various lengths plastic optical fibers into a metallic, 1000 $\mu$ m, ST™ fiber optic connector for plastic fiber.

## 2- OBJECTIVE:

This is an exercise. It is intended to develop your manual dexterity while teaching you the proper installation of an ST connector on the ends of a **plastic optical fiber**

Students are expected to pay attention to the proper way to install the connector on the fiber. This must be done in a way that will ensure longevity and prevent premature failure of the fiber optic link.

Students will use room temperature epoxy and mechanical crimping to secure the fiber firmly into the connector. Oven cured epoxy may not be used with plastic fiber.

Each student (or group of students, depending on the available budget) will prepare 9 optical fibers of various lengths. Later in this manual, you will use these same fibers to perform other experiments.

## 3- PURPOSE:

We introduced this exercise to teach you the importance of installing connectors on optical fibers. Without connectors, there will be no reliable way to align two fibers. Alignment is important to permit the transmission of an optical signal between two fibers or between a fiber and a transmit or receive instrument.

Connectors are the weakest link for a signal in a fiber optic line. It is where maximum power losses may be found. You will learn that it is worth your while to understand and practice proper connector installation to avoid unnecessary service calls.

Unnecessary service calls may annoy an engineer and will eat away at the profit margin of a contractor who is responsible for the performance of an installation.

## 4- TUTORIAL:

Typically, optical fiber is made of thin and solid strands of glass. In this case, we are using plastic optical fiber with 1000 $\mu$ m diameter. The hole in the ST connector is also 1000 $\mu$ m in diameter.

Plastic optical fiber is not popular in long distance nor is it popular in high frequency applications. In long distance applications, it exhibits unacceptable losses, this is called **attenuation**. In high frequency applications, it exhibits greater pulse distortion,

this is called **modal distortion**. At this writing, a type of plastic optical fiber called “*graded index plastic optical fiber*” is underdevelopment. It promises to perform satisfactorily at substantially higher frequencies but over a distance of only 100 meters or less. So as you can see, while it may be useable at higher frequencies, its application will continue to be limited to a short distance. i.e.: from the street to the home.

Not only its higher losses, but also its large core diameter contribute to the poor performance of plastic optical fiber. In a large core fibers, a large number of modes is transmitted inside the core. Each of these modes will travel a different optical path. These optical paths are unequal. This is what gives rise to **modal distortion**.

Again, none of these optical paths is equal in length. This causes different segments of a single optical signal (one flash of light, one bit) to exit from the output end of the fiber at different times, thus distorting the optical pulse. This will also cause an overlapping of adjacent optical pulses.

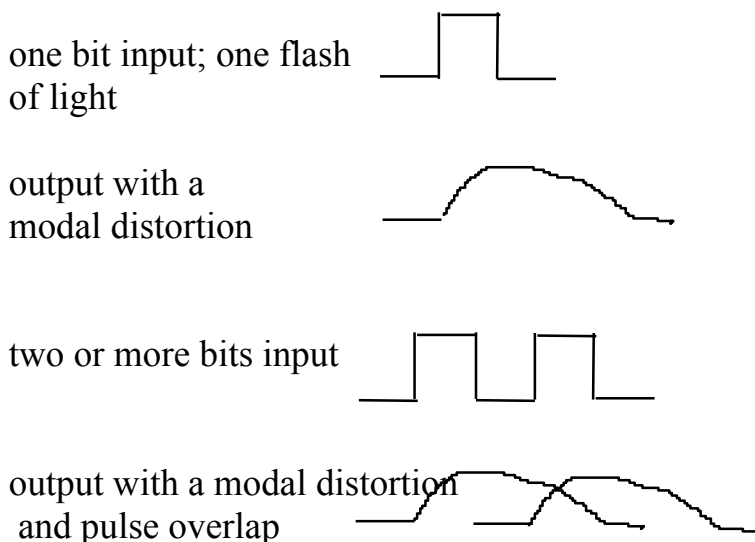

The number of modes for each data bit in a multimode fiber is given by the “M” number of the fiber. The “M” number is given by the “V” number of the fiber:

$$M = V^2 / 2 \quad \text{True only for values of } V \geq 10$$

$$V = [(2 \pi a) / \lambda ] \sqrt{n_1^2 - n_2^2}$$

$n_1$  and  $n_2$  are the indices of refraction of the core and cladding, respectively.  $a$  is the core radius and  $\lambda$  is the free space wavelength.

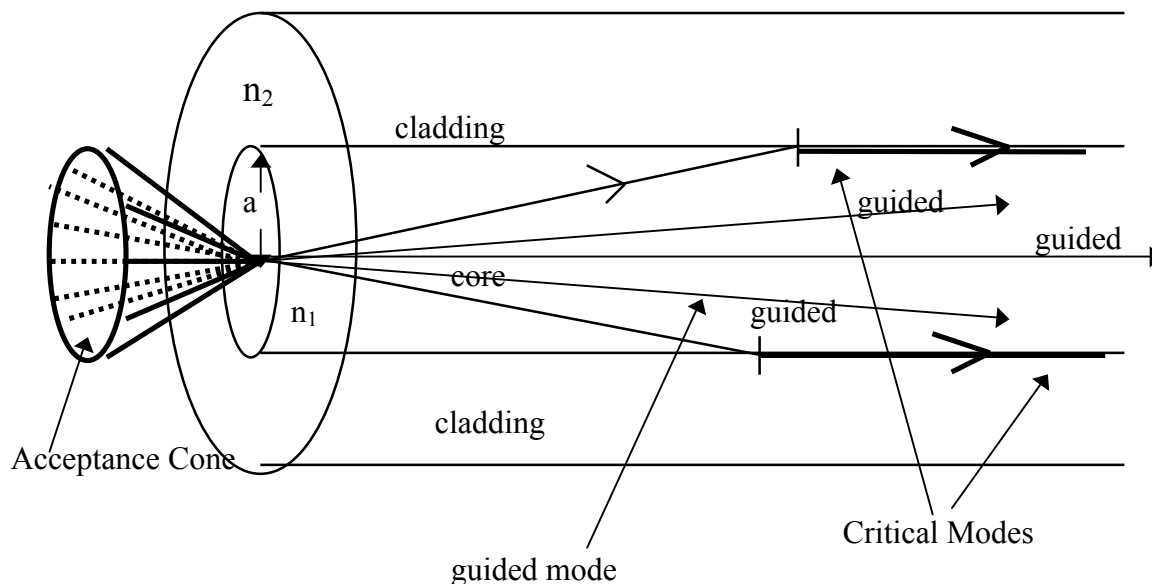

### 5- THEORY:

The theory of connector making is a combination of mechanical and optical skills. Mechanically, the connector must be easy to assemble and use. It must withstand repeated cycling and various environmental conditions. Today, connectors are being made from stainless or other metallic materials. Also, ceramic and composite materials are used often. Connectors for plastic optical fiber are also found as “all plastic” or “all metallic” connectors.

A large variety of connectors are found and/or being developed for glass optical fiber. Some plastic optical fiber uses a plastic “snap in” connector. Also, the standard ST connector with a modified hole diameter is used to accommodate the plastic fiber.

Optical concerns in connector making are related to the surface preparation of the connector which may cause pulse distortion. These are higher level concerns that do not come into play in common typical applications. And most certainly, they do not come into play in plastic optical fiber.

Remember, this exercise is intended to develop your manual dexterity and introduce you to the installation of connectors (in their simplest form) on an optical fiber.

**6- MATERIAL:** Each group of 2 or 3 students needs the following:

30 meter of plastic optical fiber  
18 AT&T ST stainless optical fiber connectors, 1000 $\mu$ m hole  
2 pads of alcohol wipes  
Epoxy, room temp cure or UV cure. (not oven cure)  
Single edge razor blade  
Suitable crimp tool

**OVERVIEW:**

- \* Each student will prepare three or more different lengths of plastic optical fiber.
- \* Students will work in groups of 2s or 3s.
- \* Each fiber will have an AT&T ST style connector on each end.
- \* When completed, each group will have nine terminated fibers of different lengths as follow:

0.1m, 0.5m, 1m, 2m, 3m, 4m, 5m, 6m and 7m

**7- PROCEDURE:**

**Cut** fibers longer than the desired lengths by about 5 cm. This will allow approximately 2.5 cm of fiber to come through the front ferrule of each connector on either side of the cable.

**Strip** the outer jacket from either end of the fiber a distance of about 5 cm.

**Feed** the fiber through the connector as a “dry run” That is to see if the fiber fits<sub>x1</sub> and all of the dimensions are as you want them.

\*When all of the dimensions are as you want them, **wipe** the fiber clean with alcohol before you apply the epoxy (epoxy will not bond to “oily” glass or plastic).

**Mix** the epoxy in accordance with the epoxy manufacturer’s specs. “**Scoop**” epoxy with the portion of the bare fiber and outside jacket that will be inside the connector.

\*Take special care not to let epoxy *contaminate* the outside of the connector.

\*If you get epoxy on the outside of the front ferrule, it will no longer fit into the receptacles of the instruments.

\*If you get epoxy on the spring or spring housing of the connector, you will not be able to lock the connector into position.

This is a detailed sketch of the ST connector and the expected position of the fiber in it. Below this sketch is a simplified one that shows the two connectors at either end of a cable.

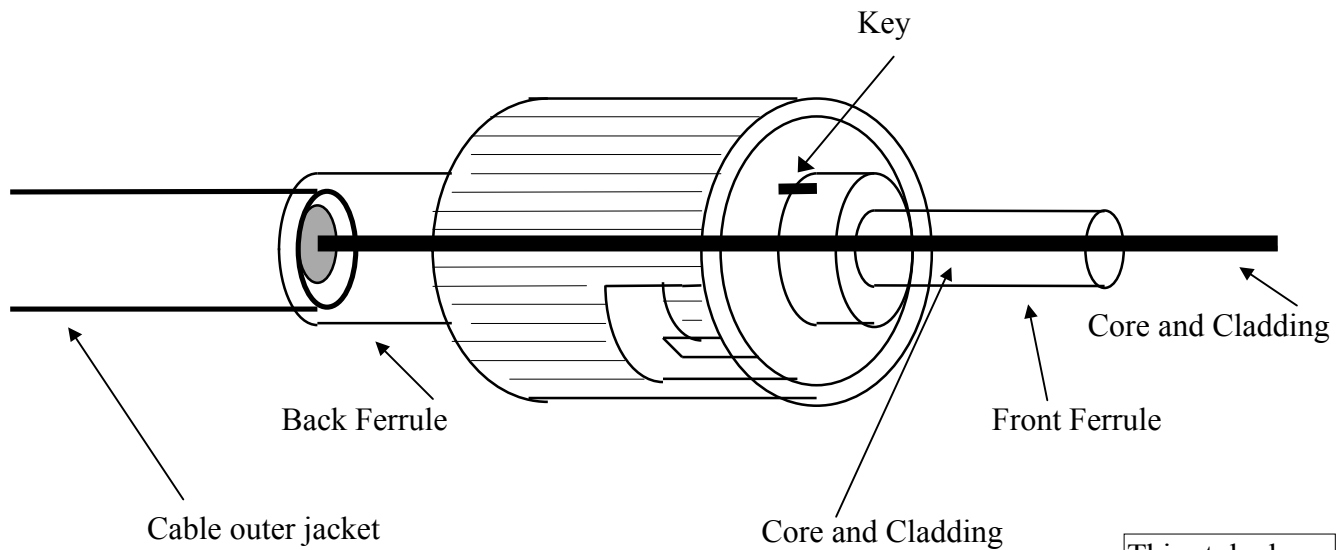

This style does not have a separate crimp sleeve

This is the AT&T ST connector.

This is the *STRAIGHT BODY* style.

Plastic optical fiber is made of a plastic core surrounded by a plastic cladding. The two are housed inside an outer protective jacket. No other protective or strength member is present. Glass optical fiber have additional strength members built into the cable. This makes the termination of plastic optical fiber the easiest of all fibers.

The epoxy is used to “bond” the plastic fiber to the inside walls of the connector and the mechanical crimping is intended to increase that bonding where the cable’s outer jacket meets the back of the connector.

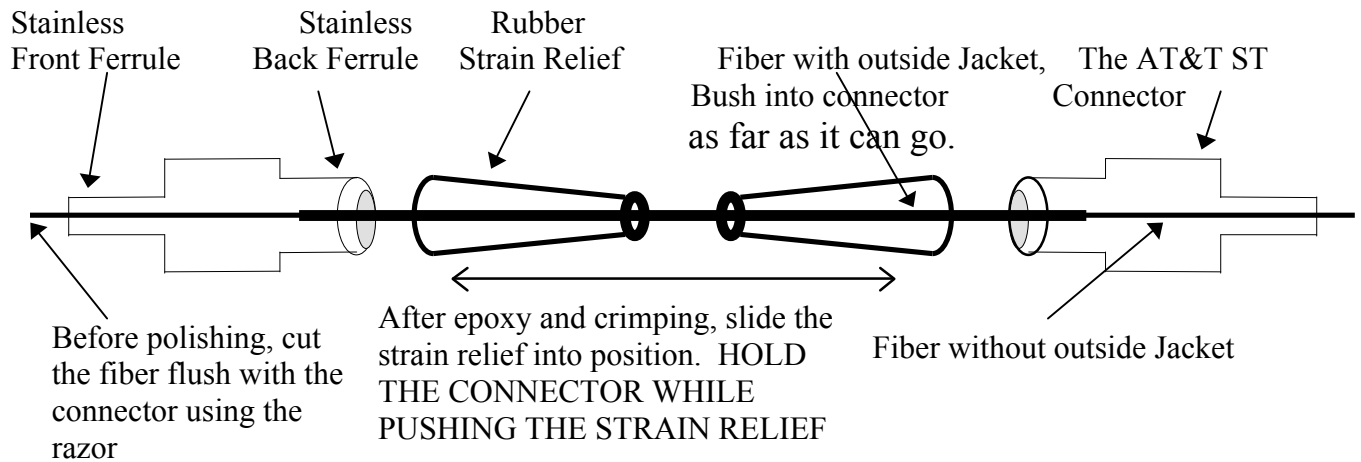

Apply the epoxy, insert the fiber into the connector, crimp ASAP and let stand to cure in accordance with the epoxy specifications. About 15 min. or more.

Slip the strain relief while holding the connector. I said while **holding** the connector.

Cut the fiber flush at the tip of the front ferrule.

**KEEP THE FIBERS CLEAN, NO FIGURE PRINTS AND NO SCRATCHES.**

Wipe clean with alcohol, Place the dust cover on all connectors and keep all cables in a safe place for future experiments.

### 8- CALCULATION:

In this exercise, there are no calculations to be performed.

### 9- RESULTS:

Typically, the results of a laboratory exercise gives the student the opportunity to contrast the actual outcome to the anticipated outcome quantitatively. This does not apply in this exercise.

### 10- DISCUSSION:

Student: Please write a short discussion. Describe, in your own words, if you had to, how you would re-write this lab. What you would change in it, and how, to make it easier and clearer for another student to do this lab. What *technical* and *practical* advice would you give to someone intending to do this exercise.

### 11- CONCLUSION:

Students: Please write a conclusion about this exercise. Contrast what was intended (as you understood it) to what was accomplished. Explain the reason(s) for any differences between the two. In addition, offer recommendation(s) on how to make the outcome coincide with the objective. Do that so others doing this exercise will be able to make use of your recommendations to achieve better match between the objective and conclusion.



# Lab Exercise 2

## TITLE:

Polish and visually inspect terminated plastic optical fibers  
“from the previous laboratory exercise.”

## OBJECTIVE:

This is an exercise. It is intended to develop your manual dexterity while teaching you the proper procedure for polishing terminated **plastic optical fiber**.

Students are expected to follow the instruction to the proper way to *polish* and *protect* the fiber and the connector in which it is housed. This must be done so as to maximize the performance of the fiber link at the connection point.

Students will use 12 $\mu$ m Aluminum Oxide polishing film. All polishing will be dry polishing. No lubricating liquids will be used.

Each student will polish one or several fibers of various lengths. This depends on the number of fibers and the number of students in each group.

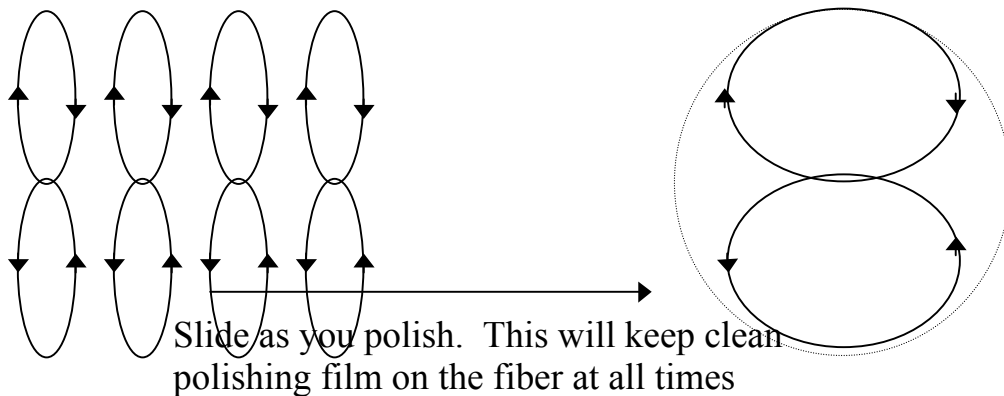

Polish using figure 8 motion as shown. **Actually**, the height and width of the figure 8 should fit into an imaginary circle as shown on the right above.

KEEP IT CLEAN at all times, touch only with cleaning material  
Do not transport contamination from one polishing film to the  
next. Always clean your polishing fixture with alcohol wipe.

### PURPOSE:

We introduced this exercise to teach you the important points when polishing optical fibers. Student should remember that there are some differences in polishing plastic and glass optical fibers. In this exercise, you are polishing plastic optical fiber. Look for additional details when polishing glass optical fiber in the future.

Connectors are the weakest link in a fiber optic line. You will learn that it is worth your while to understand and practice proper connector polishing and protection techniques to avoid unnecessary service calls and to maximize the system's performance.

Unnecessary service calls will eat away at the profit margin of a contractor who is responsible for the performance of an installation. Poor system performance will eat away at the power budget of the system and may require increased operating power.

### TUTORIAL:

Typically, optical fiber is made of thin and solid strands of glass. In this case, we are using plastic optical fiber with 1000 $\mu$ m diameter. The hole in the ST connector is also 1000 $\mu$ m in diameter.

Plastic optical fiber is not popular in long distance nor is it popular in high frequency applications. In long distance applications, it exhibits unacceptable losses, this is called **attenuation**. In high frequency applications, it exhibits greater pulse distortion, this is called **modal distortion**. At this writing, a type of plastic optical fiber called "graded index plastic optical fiber" is underdevelopment by a company just outside the Boston, Massachusetts area and it promises to perform satisfactorily at substantially higher frequencies up to a distance of 100 meters. So as you can see, while it may be useable at higher frequencies, its applications will continue to be limited to a short distance.

Not only its higher losses, but also its large core diameter contribute to the poor performance of plastic optical fiber. In a large core fibers, a large number of modes

is transmitted inside the core. Each of these modes is traveling a different optical path.

None of these optical paths is equal in length. This causes different segments of the optical signal to exit from the fiber at different times, thus distorting the optical pulse. This will also cause an overlapping of adjacent optical pulses.

Optical power may be lost from the core of a fiber due to various reasons. One of these reasons is the radiation of higher order modes into the cladding. In the cladding, these modes will attenuate rapidly and be lost for ever.

In multi mode fiber (such as we are using in this exercise) higher order modes are always present and are vulnerable to radiating out. Poorly polished connector may give rise to and promote the development of higher order modes and perhaps the conversion of these modes into a non-guided modes, they will become lost modes.

In the figure below, you can see that the difference between the guided and unguided modes is the angle at which the light is incident. Again, a poorly polished connector may very well promote the conversion of guided modes into an unguided ones.

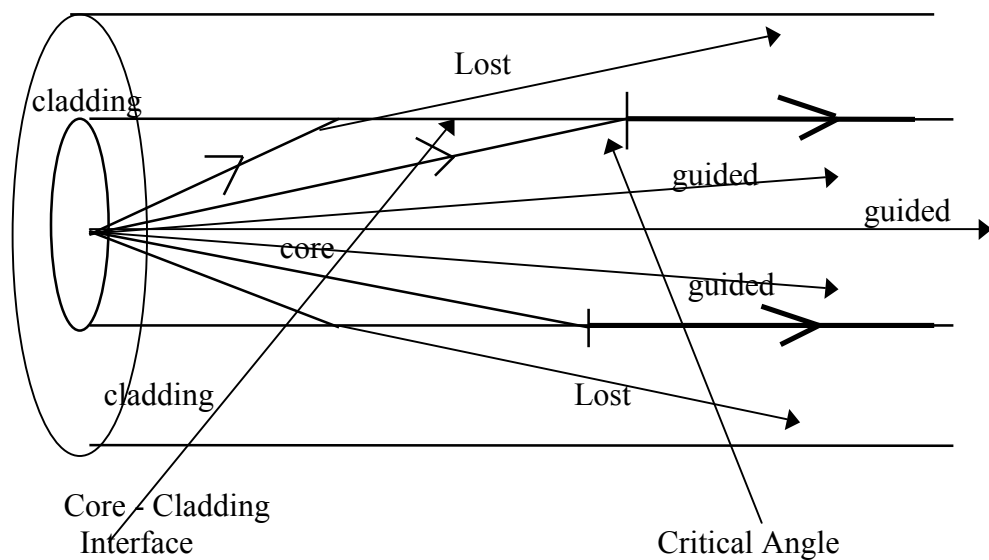

When the  
CRITICAL ANGLE is decreased,  
light will enter the cladding  
and it will be lost

When the  
CRITICAL ANGLE is increased,  
light will enter the core  
and it will be guided

### THEORY:

The theory behind polishing glass or plastic optical fiber is very simple. Use fine grit polishing film to take out all of the surface scratches and irregularities. Leave the surface of the fiber and connector flat, smooth and in the same plan.

Under such circumstances, when two fibers are brought close together, their surfaces will touch and make a full and smooth contact to allow the optical energy to cross from one to the next with only minimum loss.

A large variety of connectors are found and/or being developed for glass optical fiber. Plastic optical fiber has a plastic “snap in” connector and the standard ST connector with an enlarged hole to accommodate the plastic fiber.

Remember, this exercise is intended to develop your manual dexterity and introduce you to the polishing and inspection technique of a plastic optical fiber.

MATERIAL: Each group of 2 or 3 students needs the following:

- 6 sheet Aluminum Oxide polishing film 12 $\mu$ m grit size
- 1 hard but smooth polishing surface such as glass for each student.
- 6 pads of alcohol wipes
- 1 suitable polishing fixture for each student
- 1 suitable inspection microscope with 60 or 100X magnification.

## OVERVIEW:

- \* Each student will polish one or more connector depending on the total available
- \* Students will work in groups of 2s or 3s.
- \* Each end of each fiber will be polished and inspected several times.
- \* When completed, each group will have nine terminated and polished fibers of different lengths as follow:  
0.1m, 0.5m, 1m, 2m, 3m, 4m, 5m, 6m and 7m

- \* When polishing one end of the fiber, make sure the opposite end protected so it will not drop on the floor, drag, collect dust or scratch.

## PROCEDURE:

You had cut the fibers longer than the desired lengths by about 5 cm. This allowed approximately 2.5 cm of fiber to come through the front ferrule of each connector on either side of the cable. Now, cut that piece (the 2.5 cm) flush with the surface of the connector using a razor. You may have already done that in the previous lab.

It is recommended at this point to inspect the cut and unpolished fiber with the microscope. USE ONLY ROOM LIGHT to inspect the fiber. Follow the microscope manufacturer's instruction. This will allow you to see what the fiber looks like prior to polishing and give you an appreciation to the importance of polishing.

Place the connector through the hole in the polishing fixture, be sure the tip of the front ferrule sticks out from the other side of the polishing fixture.

The polishing fixture will secure the fiber and connector at 90° to the polishing surface. You must ensure that the polishing fixture stays flat on the polishing surface.

Start polishing by making figure 8 motion on the polishing film. Note: the height of the figure 8 must equal its width

Apply moderate pressure on the polishing film.

Ensure that the tip of the connector, and thus the fiber, is in continuous contact with the polishing film at all times.

Ensure that the polishing fixture does not lift off of the polishing film when making figure 8.

Do five or so laps of figure 8.

Stop.

Clean the tip of the fiber with alcohol.

Inspect with a microscope. allow ROOM light to enter the fiber on one end while inspecting the other end with the microscope.

Repeat the process, polish, stop, clean, inspect and polish again. Monitor and observe the progress of the surface being polished.

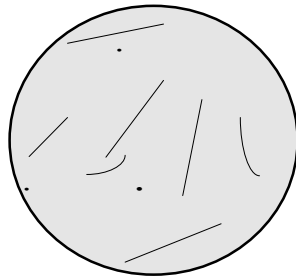

Polished plastic optical fiber will look like this. There will always be some minor scratches. The large cross section area of plastic fiber allows you to ignore these scratches.

You may not ignore them in glass optical fiber

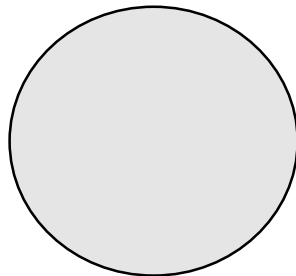

Polished plastic optical fiber with no visible scratches. In most cases, this is hard to achieve and is not worth the effort for plastic fiber.

KEEP THE FIBERS CLEAN, NO FIGURE PRINTS AND NO NEW SCRATCHES. Wipe clean with alcohol, Place the dust cover on all connectors and keep all cables in a safe place for future experiments.

### 8- CALCULATION:

In this exercise, there are no calculations to be performed.

### 9- RESULTS:

Typically, the results of a laboratory exercise gives the student the opportunity to contrast the actual outcome to the anticipated outcome quantitatively. This does not apply in this exercise.

### 10- DISCUSSION:

Student: Please write a short discussion. Describe, in your own words, how you would re-write this lab, if you had to. What you would change in it and why. What advise would you give to someone intending to do what you had just finished.

### 11- CONCLUSION:

Students: Please write a conclusion about this exercise. Contrast what was intended to what was accomplished. Explain the reason(s) for any differences between the two. In addition, offer recommendation(s) on how to make the outcome coincide with the objective. Do that so others doing this exercise will be able to make use of your recommendations and observations to achieve better match between the objective and conclusion.

# Lab Exercise 3

## TITLE:

Power launching and the testing of optic power loss between two plastic optical fibers in ST connectors

## OBJECTIVE:

This is a laboratory experiment. It is intended to develop your understanding of the testing methodology and the testing and calculation procedure relating to optical power loss between two terminated **plastic optical fibers**.

Students are reminded that there are several methods used to test connector loss. In this lab, we are using the “launch cable method” without mode stripping, the simplest one of all. In future labs, we may revisit this subject and use a different testing procedure.

Students will test the connector loss of only the shortest plastic fibers individually, develop understanding of the connector loss, testing procedure and calculate the loss value in different units.

## PURPOSE:

Optical power loss in optical fibers is the reason we use regenerators or amplifiers in the line. Most of the power loss usually occurs at the point of connecting two fibers. It is important that the loss at this connection point be kept to a minimum.. testing connector loss is essential to the understanding of how to keep it to a minimum.

Students will learn how to set up the testing procedure correctly, how to measure the loss, how to convert that loss between different units and how the loss maybe affected by outside variables.

Once the loss and the reasons behind it are understood, the student will have learned how to prevent it in future terminations.

## TUTORIAL:



1- THE UNITS OF MEASUREMENTS: In optical fiber, we use the milliWatt scale to measure the transmitted optical power. At the receiver, we may find ourselves having to use the microWatt scale to evaluate the received optical power. The reason for selecting these units is very simple. They are just the right “size” for the technology today. We need not have one nor several Watts of power to get today’s optical communication systems to perform.

Another unit of measure is the deciBel, also known as dB. The dB is used to measure the relative change of power between two points in a link.

$$10 \text{ Log}_{10} \frac{P_2 \text{ in watts}}{P_1 \text{ in Watts}} = \text{is given the unit of deciBel, dB, which may have a positive or a negative value}$$

Here, students are reminded that half the power is lost for every 3dB drop. Also, you are reminded that in the definition above, its value will be + if  $P_2 > P_1$  and - if  $P_2 < P_1$

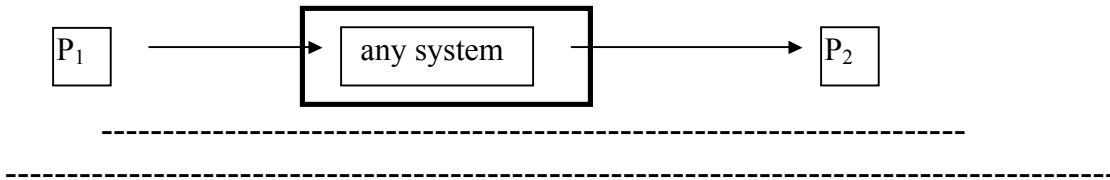

Since the typical optic power used in fiber optic communication systems is in the mW range, we need to modify the dB unit above only to inform the reader that we are using the mW and not any other range. If you **fix the value of  $p_1$  to 1 mW**, the equation above will now be written as follows and the units will be referred to as dBm

$$10 \text{ Log}_{10} \frac{P_2 \text{ of any value}}{1\text{mW}} = \text{is given the unit of deciBel}_m \text{ or dB}_m$$

This is **not a millideciBel**, it is a deciBel referenced to 1 mW. Here, students are also reminded that half the power is lost for every 3dB drop. That is, if the power drops from 1 mW to a 0.5 mW, we say the drop is 3dB and that puts

us at the -3dBm point. And if the power drops by a half again, we say the total drop is 6dB and that puts us at the -6dBm point or 0.25 milliWatt.

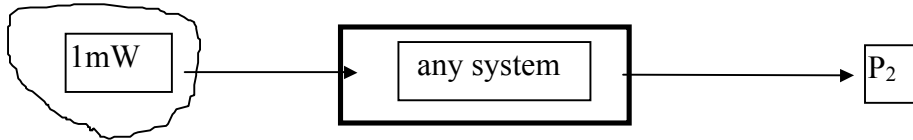

EXAMPLE: What would be the dBm reading of a 2mW optical signal

SOLUTION: using the definition we write:

we write:

$$10 \text{ Log}_{10} \frac{P_2 \text{ of any value}}{1\text{mW}} = \text{is given the unit of deciBel}_m \text{ or dB}_m$$

Anytime you fix the denominator to 1mW, your answer is in dBm

$$10 \text{ Log}_{10} \frac{2 \text{ mW}}{1\text{mW}} = 3.01 \text{ dBm} \approx 3 \text{ dBm}$$

*AN EXAMPLE for you: How many dBm is there in 1 mW of an optical signal.*

*Do this example and pass it in to your teacher with your lab write-up*

2-THE MISALIGNMENT ISSUE: One cause for optical power loss between two fibers is the misalignment of the two fibers. Misalignment can be caused by improper polishing which may have caused the surface of the fiber to be at an angle

other than 90° with respect to its axis. This angular misalignment can also be caused by the improper alignment of the two connectors.

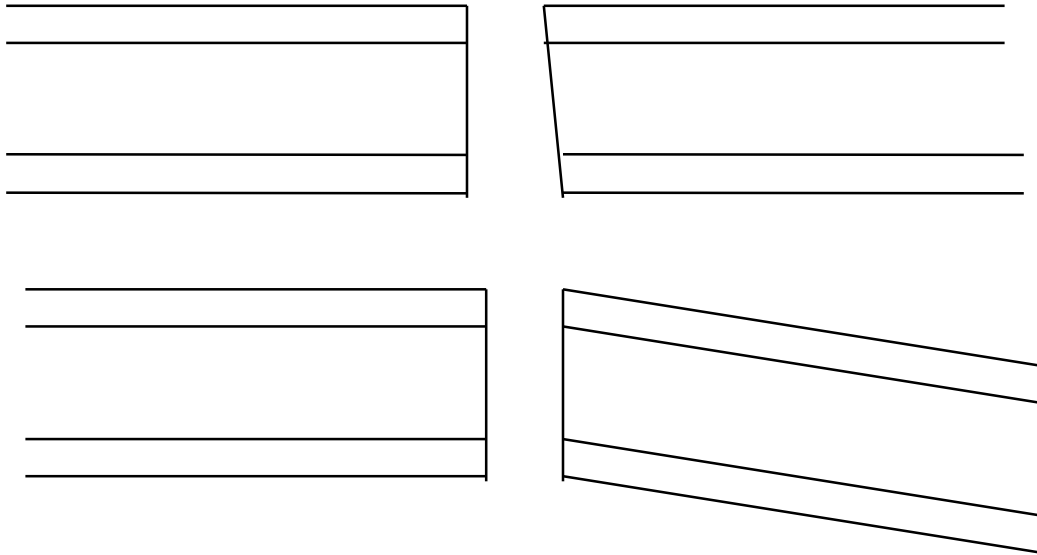

In addition to the issue of angular misalignment, we have to be concerned with axial misalignment. These deficiencies will be induced and studied in later experiments.

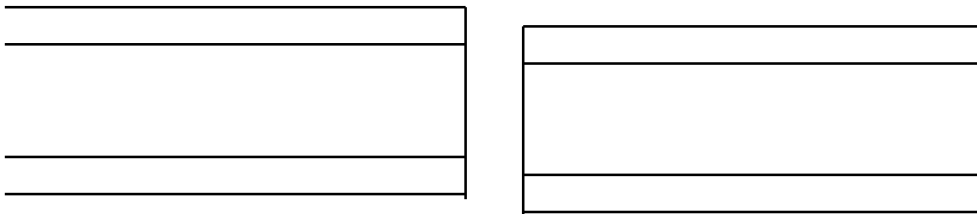

3- THE QUALITY OF THE SURFACE: Another possible cause for optical power loss is the issue of surface quality and preparation. Dirt, dust, finger prints, any form of contamination, and scratches on the surface contribute to the poor power transfer from one fiber to the next.

Assuming you are testing two fibers of the same type, the same core size and parameters, one or more of the variables referenced above will be a cause for power loss. Connector loss measurements with mismatched fibers will be studied in a different lab experiment.

4- MODE stripping is yet another possible cause for *apparent* connector power loss. This is a real issue and it may mislead the technician when testing connectors for loss. Future lab experiments will take into account this variable.

**THEORY:**

As optical power exits from an optical fiber, it exits at an angle described by Snell's law for ray optics. Provided the fibers are fully aligned and the surfaces are just so perfect, maximum power will be transferred from one fiber to the next. Under such conditions, the loss will be limited to the inherent scattering and reflection.

Under such circumstances, when two fibers are brought close together, their surfaces will touch (most but not all connectors are designed to allow physical contact between the two fiber surfaces) and make a full and smooth contact to allow the optical energy to cross from one fiber to the next with only minimum loss.

When the surfaces are flat and clean, excessive loss may be due to axial misalignment. This is represented in these two overlapping circles.

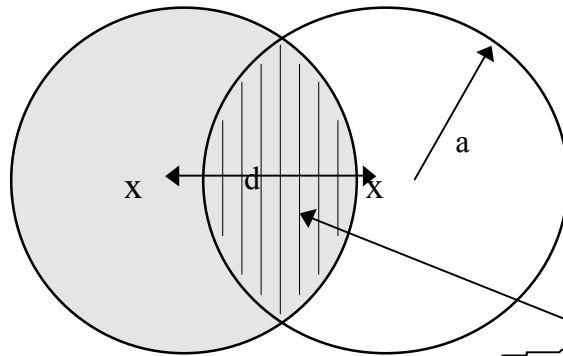

TWO OVERLAPPING FIBERS WITH THE COMMON SURFACE AREA  $A_c$ , IN THE MIDDLE.

In step index fiber, which this is, the optic power loss is a function of the coupling efficiency. The coupling efficiency is the ratio of the core surface area  $A$  divided by the common surface area  $A_c$

$$A = \pi a^2$$

$$A_c = 2a^2 \cos^{-1} d/2a - d \sqrt{a^2 - (d^2/4)}$$

### MATERIAL:

- 1 set LED power source and a power meter
- 1 set of ST adapters for the source and meter
- 1 ST to ST cable adapter

### OVERVIEW:

- \* Each group will select the shortest cable as their launch or test cable
- \* calibrate the meter against the power at the output of the best launch cable
- \* Each group will test the connector loss of only the shortest cable they have
- \* All students in class will work as on group
- \* Each end of each of the short fibers will be tested against the Standard launch cable.
- \* NOTE: Losses in plastic fibers are inherently too high. Trying to test for connector loss requires that you know the fiber loss and you take it into account. The effect of this factor will be reduced by testing only the connectors on the shortest fibers.

### PROCEDURE:

Write your group name or number on the cable.

Mark both ends of the cable as “a” and “b”

STEP ONE: Connect the source and the meter with the *shortest* fiber, as shown, with the “a” end into the source. Be sure the fiber is clean and free from dirt and dust.

Record the reading from the meter

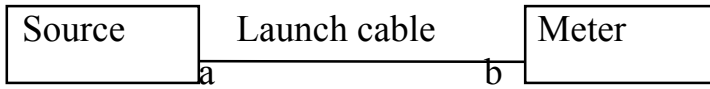

Remove and reinstall the cable with its “b” end into the source as shown below

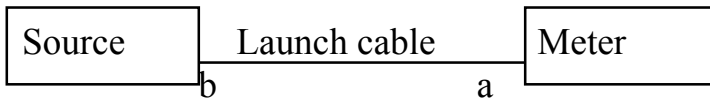

Complete the table below

Selecting the best launch cable:

table for STEP ONE

Meter read in dBm, $P_1$			
Group name	“a” end into the source	“b” end into the source	comments

Analyze the readings above and **select the fiber and orientation** with the least loss. For example, a reading of -7dBm is better than a reading of -8dBm

Lets say the selected cable and orientation is that of your group. Now, the rest of the class will make and use your cable as the launch cable as shown below.

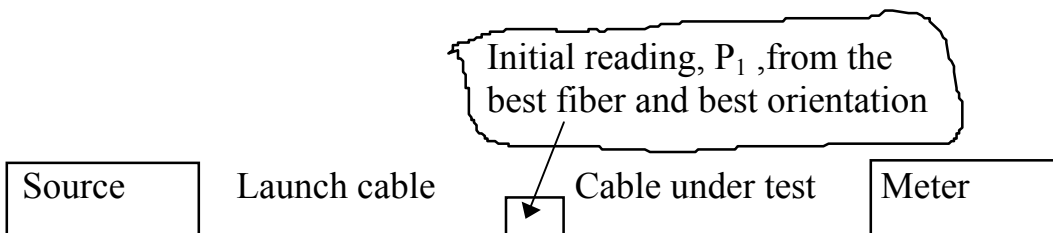

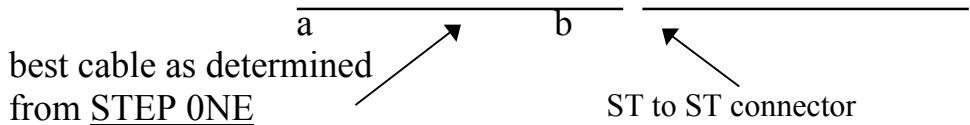

DO NOT DISTURB THE CONNECTION AT THE SOURCE END.

STEP TWO: Insert the “cable under test” between the ST to ST connector and the meter one at a time. Try both ends of the cable one end at a time. Record your readings in the table below and calculate the power loss for each connector.

Remember, your initial reading,  $P_1$ , is the starting power level found in STEP ONE

Connector loss record

table for STEP TWO Meter read in dBm,  $P_2$  “a” in source, “b” in source

Group name	“a” end into the source	“b” end into the source	Connector loss	
			$P_1 - P_2$	$P_1 - P_2$

KEEP THE FIBERS CLEAN, NO FIGURE PRINTS AND NO NEW SCRATCHES. Wipe clean with alcohol, Place the dust cover on all connectors and keep all cables in a safe place for future experiments.

8- CALCULATION:

In this lab experiment, you are required to calculate the power loss of each connector by subtracting  $p_1 - p_2$

Example calculation:  $P_2 = -8\text{dBm}$ ,  $P_1 = -7\text{dBm}$ . Find the connector loss

Connector loss =  $P_1 - P_2 = -7 \text{ dBm} - -8 \text{ dBm} = 1 \text{ dB}$ . So now we can say the power level is at  $-8 \text{ dBm}$  and the connector loss is  $1 \text{ dB}$

STEP THREE Also, convert all of the dBm readings to the corresponding values in watts and milliwatts. Construct a table, organize and present all calculations.

table for STEP THREE when you complete this table, you will never forget how to convert between dBm and mW; even under the stress of a surprise quiz.

P <sub>2</sub> , “a” in source		P <sub>2</sub> , “b” in source		connector loss, “a” in		connector loss, “b” in	
dBm	mW	dBm	mW	dBm	mW	dBm	mW

9- RESULTS:

Typically, the results of a laboratory exercise gives the student the opportunity to contrast the actual outcome to the anticipated theoretical outcome quantitatively. This does not apply in this exercise. Instead, outline the results of this lab by tabulating the loss of the connectors in the class.

10- DISCUSSION:

Student: Please write a short discussion. Describe, in your own words:

How, if you had to, would you re-write this lab.



What you would change in it and why.

What advise would you give to someone intending to do what you had just finished.

Also, offer helpful hints on the handling and testing of connectors.

### *11- CONCLUSION:*

Students: Please write a conclusion about this exercise.

Contrast what was intended to what was accomplished.

Explain the reason(s) for high connector loss you or others may have had.

In addition, offer recommendation(s), based on your observations and experience, on how to minimize high connector loss .

Do that so others doing this exercise will be able to make use of your recommendations and observations to achieve better results.

# Lab Exercise 4

## 1- TITLE:

Measuring optical power attenuation in your plastic optical fiber

## 2- OBJECTIVE:

This is a laboratory experiment. We are planning to develop your understanding of the testing methodology and the testing and calculation procedure relating to optic power loss in **optical fiber**. In this case, we are using plastic optical fiber

Students are reminded that there are several methods used to test attenuation in optical fiber. we are using the simplest one of all, but this is the best non destructive approach. Other more reliable method, such as the cut back method, require cutting pieces of the fiber.

## 3- PURPOSE:

Optical power loss in optical fiber is the reason we use repeaters in the line. Most of the power loss usually occurs at the point of connecting two fibers. It is important that the loss at this connection point be kept to a minimum.. In the case of plastic optical fiber, power loss inside the fiber is substantial and it may exceed the loss at the connection point of two fibers.

Students will learn how to set up the testing procedure correctly, how to measure the loss, how to convert that loss between different units and how the loss maybe affected by outside variables.

Once the loss and the reasons behind it are understood, the student will have learned how to prevent it or at least account for it in the power budget calculation.

## 4- TUTORIAL:

Optical power is launched into an optical waveguide to be transported to another location. On its way to that other end of the fiber, individual photons will be lost for a variety of reasons.

In this experiment, we will know the total power loss in the plastic optical fibers but we will not know the amount of loss for each of these various factors.

Since optical fibers are uniform in some sense, we expect the loss in them to be equally uniform. It may be high or low but it will be uniform. This should allow us to find a common method to identify the power loss. We identify the loss per unit length, that is we say the loss is so many dBs per meter or per Kilometer.

For plastic optical fiber we expect the loss will be very high. It would be more appropriate to measure the loss per meter not per Kilometer. For glass fiber, on the other hand, we measure the loss in dBs per Kilometer not per meter.

There are internal reasons for power loss and there are external reasons. In this experiment, we will do all we can to eliminate the external factors. External factors include the quality of the connections, the bending of the fiber and the effect of the cable on the fiber.

In its simplest form, if we can be sure of the power level entering the fiber,  $P_1$ , the power level exiting the fiber,  $P_2$ , and the length of that fiber, we can write:

$$10 \text{ Log}_{10} \frac{P_2}{P_1} = \text{Total loss in dBs}$$

Total loss in dBs divided by total distance = the common unit of dB per meter or dB per Kilometer.

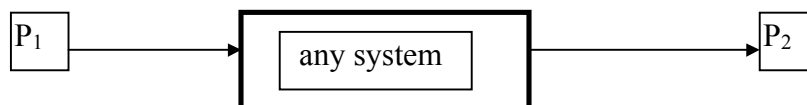

EXAMPLE: A 17 meter plastic optical fiber known to have 2.3 mW of optical power at one end and .023 mW on the other end. Find the total loss in dBs and the loss per meter for this fiber.

SOLUTION: using the equation above

$$10 \text{ Log}_{10} \frac{P_2}{P_1} = 10 \log_{10} \frac{.023}{2.3} = -20.6 \text{ dBs}$$

The minus sign signifies it is a loss

20.6dBs divide by 17 meter = 1.2 dBs per meter.

This is typical for plastic optical fiber. Glass optical fiber will have much much lower loss.

*AN EXAMPLE for you: How many dBm do you expect to find at the output of one meter of this plastic optical fiber if the input is known to have 1 mW of an optical signal. Do this example and pass it in to your teacher with your lab write-up*

## 5- THEORY:

Optical power attenuate inside optical fibers as a function of two factors. The rate of distance traveled, (the length of the fiber) and a constant related to the rate of absorption of optical energy in that particular fiber.

These rates of attenuation are exponential in nature. That is the optic power,  $P_L$ , remaining after traveling distance  $L$ , is given in the following expression as a function of the initial power  $P_0$

$$P_L = P_0 e^{-\alpha L}$$

Here,  $\alpha$  is the proportionality constant and  $L$  is the distance of travel (the length of the fiber)

The expression above uses the power in the Wattage domain not the dB domain. To convert to dBs, we must take the **log** of the ratio of Watts over Watts

$$\frac{P_L}{P_0} = e^{-\alpha L}$$

Now we take the  $\log_{10}$  of both sides and write:

$$10 \log_{10} P_L/P_0 = 10 \log_{10} e^{-\alpha L}$$

Since we can measure  $P_L$ ,  $P_0$  (not very accurately) and  $L$ , we can calculate  $\alpha$ . In this lab, we are not interested in  $\alpha$ . We will calculate that in future labs.

From the left side of the equation above, we can find the total power loss **in dBs** for each of the fiber lengths. If we divide that loss by the length, (measure the length in meters) we get the loss per meter in the form of dBs/m

You are reminded again, in glass optical fiber, we measure the loss in dB/Km not dBs/m

## 6- MATERIAL:

- 1 set LED power source and a power meter for each group
- 1 set of ST adapters for the source and meter for each group
- 1 ST to ST cable adapter for each group
- 1 set of 9 terminated fibers of various lengths for each group
  - 9 various lengths stainless ST terminated plastic optical fibers
  - 0.1m, 0.5m, 1m, 2m, 3m, 4m, 5m, 6m and 7m

## OVERVIEW:

- \* Each group will select the shortest cable as their launch cable
- \* calibrate the meter against the power at the output of the launch cable
- \* Each group will data on the output power of various lengths cables they have
- \* All students in class will work as independent groups. Compare the results from different groups

## 7- PROCEDURE:

To minimize the sources of error, be sure to keep the fiber clean, free from scratches and as straight as possible when doing the measurements.

Connect the 0.1m fiber to the source. **YOU MAY NOT REMOVE OR DISTURB THIS CONNECTION DURING THE DATA COLLECTION PORTION OF THIS EXPERIMENT.**

Connect the 0.5m fiber to the 0.1m fiber using an ST to ST coupler.

Connect the other end of the 0.5m fiber to the power meter. If you have the option, increase the power at the source to the highest level possible but be sure the power meter is not in saturation.

THE READING YOU HAVE AT THE METER IS THE INITIAL POWER LEVEL. THIS IS THE POWER LEVEL AT ZERO FIBER LENGTH.

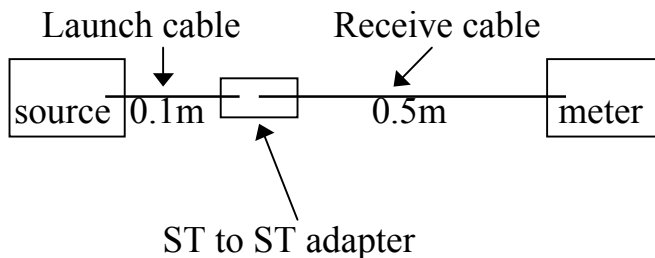

We do not know how much power is generated by the source

We do not know how much power is entering the launch cable

We do not know how much power is transferring from the launch to the receive cable

We do not know how much power is lost along the receive cable

**We only know how much power is received by the meter from the receive cable.  
THIS WILL BE THE INITIAL POWER LEVEL AT ZERO LENGTH FIBER.**

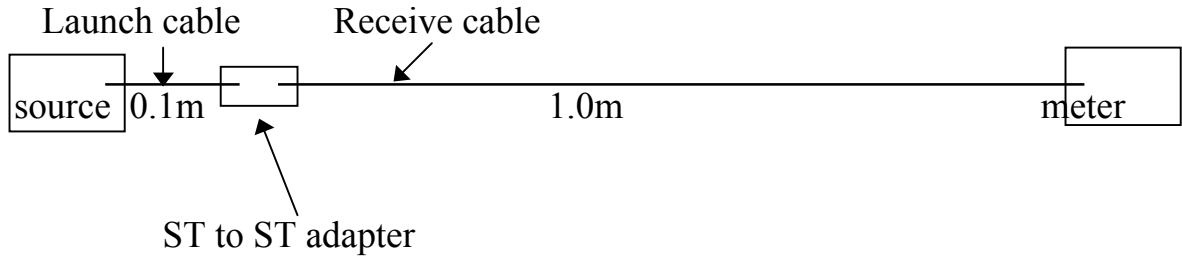

When we **replace** the 0.5m Receive cable with 1.0m Receive cable, we **increased** the fiber length by only 0.5m starting from the ST to ST adapter. Therefore, the optic power drop we read now is due to 0.5m of fiber length.

Receive cable length: 1m    Fiber length under test: 0.5m

We are using this approach to ensure that the number of connections does not increase when the fiber length is increased. Otherwise, “some” of the additional loss will have to be attributed to the additional connector. We have no way to know how much is that “some”

YES, we are making the assumption that the various connections in the ST to ST adapter are identical.

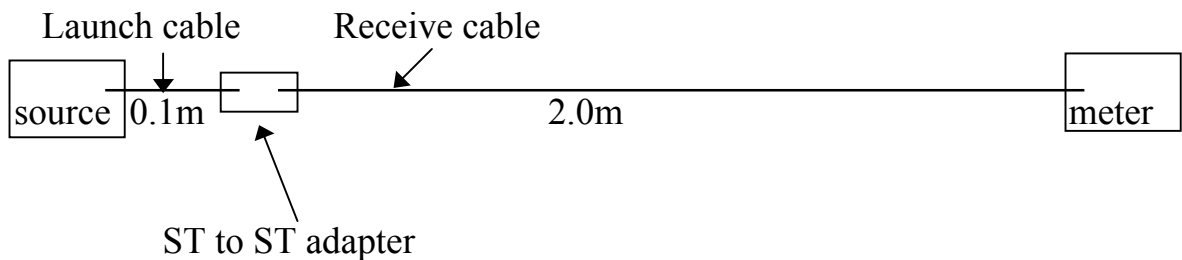

When we **replace** the 1.0m Receive cable with 2.0m Receive cable, we **increased** the fiber length by only 1.5m starting from the ST to ST adapter. Therefore, the optic power drop we read now is due to 1.5m of fiber length.

Receive cable length: 2m    Fiber length under test: 1.5m  
 Receive cable length: 3m    Fiber length under test: 2.5m



KEEP THE FIBERS CLEAN, NO FIGURE PRINTS AND NO SCRATCHES.

Place the dust cover on all connectors as soon as you are done with them and keep all cable in a safe place for future experiments.

Continue the data collection procedure and complete the table below:

Fiber Length used	length under test	power reading in dBm	power in mW calculated	power reading in dBu	power in uW calculated
1m	0.5m				
2m	1.0m				
3m	2.0m				
.	.				
.	.				
.	.				
.	.				

If your power meter reads in the Wattage domain, record the readings as such and convert them to the dB domain using the equation. If your power meter reads in the dB, dBm or dBu domains, use the equations below to calculate the missing values. If your meter reads in all of these domains, do the calculation any way to see if the meter is correctly calibrated.

$$10 \log_{10} (P_{mW}/1mW) = dBm$$

or

$$10 \log_{10} (P_{uW}/1uW) = dBu$$

If your power meter reads in the dB domain, record the readings as such and convert them to the Wattage domain using the equation

$$P_{mW} = \log^{-1}(dBm/10) \text{ times } 1mW$$

Plot the loss vs. distance twice. use distance in meters and loss in the dB domain and do it again also using distance in meters and loss in the Wattage domain.

If you have the resources, repeat this experiment using different wavelengths

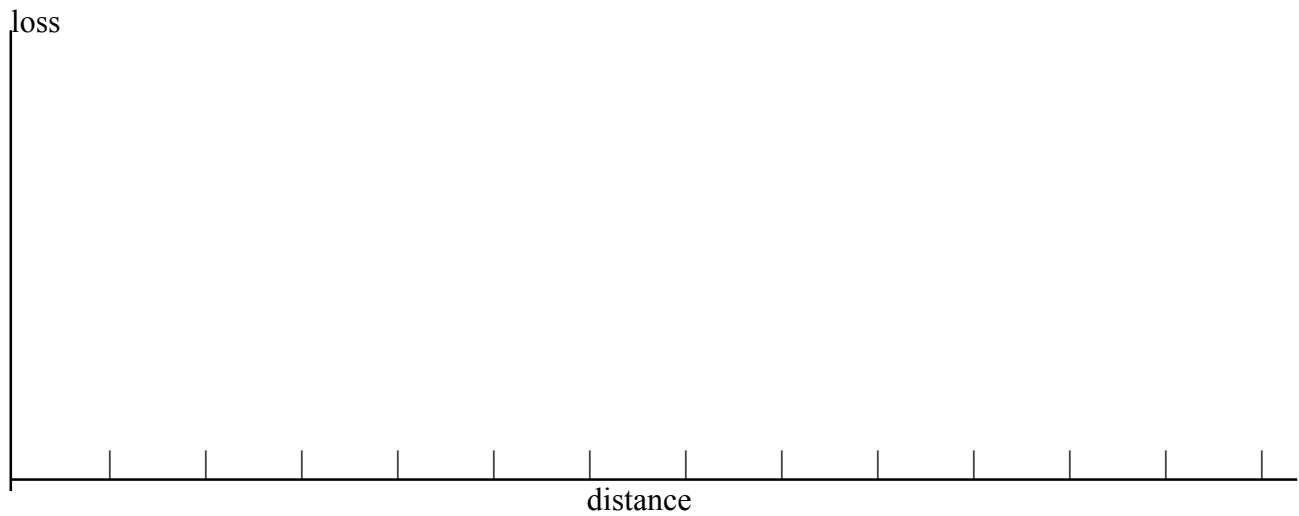
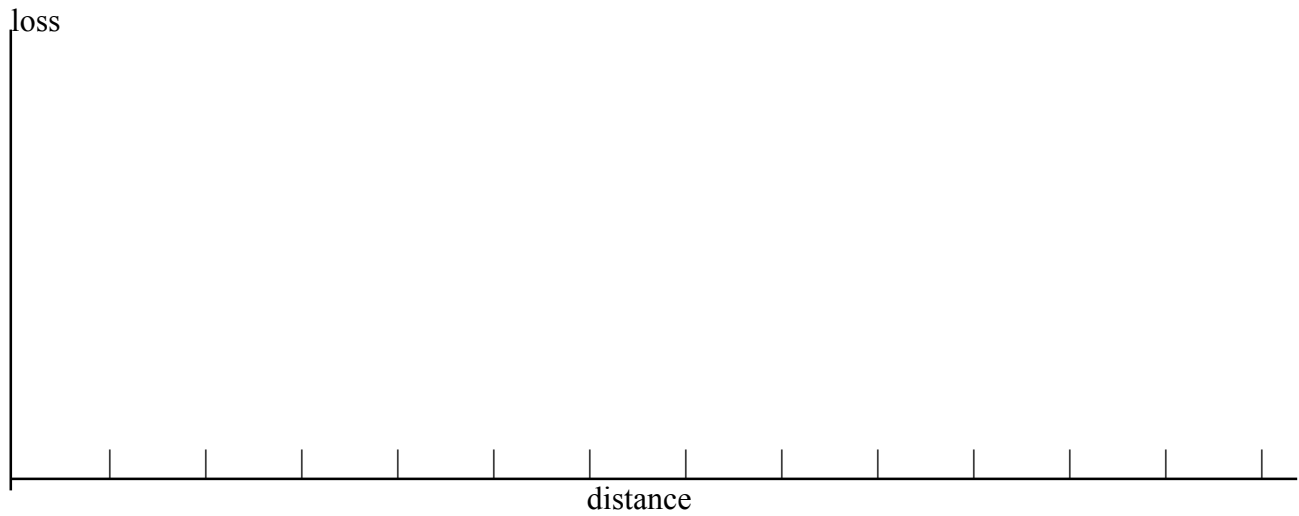

8- CALCULATION:

In this lab experiment, you are required to measure the power loss of each cable using various lengths cables. Show details in all calculations. Fill out the tables above. If your power meter gives you the option to read levels in mW, μW, dBm and dBμ, do so but also do the calculation by hand to verify that the meter is calibrated correctly.

Example calculation:

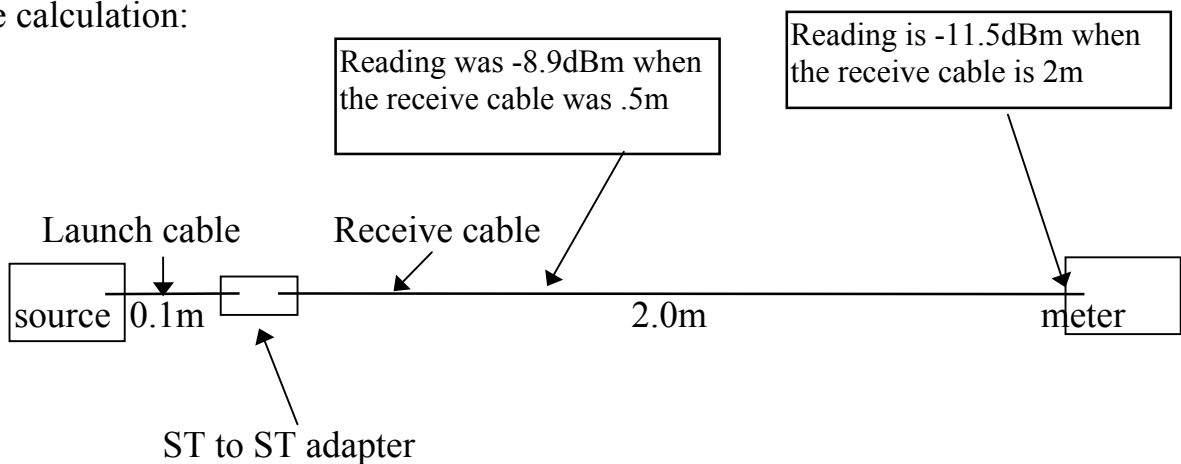

Solution: Total loss = -8.9dBm - - 11.5dBm = 2.6 dB

This 2.6 dB is due to the fact that the 2 m cable is 1.5 m longer than the .5 m cable

In this case, the loss is 2.6 / 1.5 = 1.73 dB per meter.

The - 8.9 dBm represents .128 mW, here is that calculation:

$$10 \log_{10} \frac{P}{1 \text{ mW}} = -8.9 \text{ dBm}$$

$$P = \log^{-1} (-.89) \text{ and the unit is mW} = .1288 \text{ mW}$$

Use the same method to

Show that the - 11.5 dBm represents .0707mW

In other words, the additional 1.5 m of fiber costs the signal  
 $.1288 - .0707 = .0581$  mW of optic power

### 9- RESULTS:

Typically, the results of a laboratory exercise gives the student the opportunity to contrast the actual outcome to the anticipated outcome quantitatively. This does apply in this exercise.

Outline the results of this lab by tabulating the rate of loss, in dB per meter, of the fiber of the various groups in the class. Also, seek information from the manufacturer about the known loss of the particular fiber you are using.

If your school have the resources and your class has the time, and if you have done this experiment using different wavelengths, you must repeat all of the calculations for each different wavelength. All aspects of this lab have to be addressed for the various wavelengths.

### 10- DISCUSSION:

Student: Please write a short discussion. Describe, in your own words, how you would re-write this lab, if you had to. What you would change in it and why. What advise would you give to someone intending to repeat what you had just finished.

### 11- CONCLUSION:

Students: Please write a conclusion about this exercise. Contrast what was intended to what was accomplished. Explain the reason(s) for any differences between the two. In addition, offer recommendation(s) on how to make the outcome coincide with the objective. Do that so others doing this exercise will be able to make use of your recommendations and observations to achieve better match between the objective and conclusion.

# Lab Exercise 5

## 1- TITLE:

Measuring the Numerical Aperture, NA of your plastic optical fiber

## 2- OBJECTIVE:

This is a laboratory experiment. We are planning to develop your understanding of the testing methodology and the testing and calculation procedures relating to the measurement of the Numerical Aperture of **optical fiber**. In this case, we are using STEP INDEX plastic optical fiber.

Students are reminded that the general idea for measuring the NA of an optical fiber is to rotate the fiber angularly with respect to the source. You will do just that. The more accurate an answer you need, the more precise an apparatus you must have.

## 3- PURPOSE:

Optical power intended to be launched into a fiber may and may not enter the fiber. To enter the fiber, light must strike the surface of the fiber at an angle suitable for that particular fiber. When making sources, or focusing light and aligning it up with the fiber, one must take that into account. When inspecting the fiber visually, you must orient it properly (rotate it) to the light fixture in the ceiling or else you will not be able to inspect that fiber using room light. That is room light will not enter the fiber.

When splicing or connecting fibers, it is important to splice or connect fibers of the same Numerical Aperture to minimize optical power loss.

So the primary reason for this lab experiment is to learn about the Numerical Aperture and how to measure it in a laboratory setting.

#### 4- TUTORIAL:

Optical fiber is made up of two different layers of plastic or glass. In this lab, we are using plastic. The two layers have different indices of refraction. The inner layer, the core, always has a higher index of refraction than the outer layer, the cladding. The indices of refraction are different but very close.

This difference in the index of refraction gives rise to the phenomena of TOTAL INTERNAL REFLECTION. This is the phenomena that contains, confines and guides light in the core of the fiber. In addition, that difference also defines the Numerical Aperture of the fiber. The numerical aperture also depends on the medium the fiber is in. In this case the fiber is in air.

Again, the NA of the fiber will change depending on the medium surrounding the fiber. In this case, we will assume the fiber is surrounded by air which has an index of refraction of 1.0003 but most often is considered to be 1

We have been talking about the index of refraction. What is the index of refraction anyway?

The medium index of refraction,  $n$ , is a measure of the speed of light in that medium compared to that in vacuum. In other words,

$$n = C/V$$

Since  $C$ , the speed of light in vacuum, has the units of meters per second and  $V$ , the velocity of light in a medium, also has the units on meters per second, therefore, the index of refraction is unit-less.

Also, since  $C$  is always greater than  $V$ , the index of refraction  $n$  is always greater than 1

In summary, the index of refraction is a unit-less quantity, always has a value greater than 1 (vacuum is 1) and it affects (slows down) the speed of light in that medium.

EXAMPLE: The speed of light in a medium is measured and found to be  $2 \times 10^8 \text{ ms}^{-1}$ . What is the index of refraction of that medium?

$$\begin{aligned} \text{SOLUTION: } n &= C/V &= 3 \times 10^8 / 2 \times 10^8 \\ & &= 1.5 \end{aligned}$$

Simple, the index of refraction of this material is 1.5 and this quantity is unit-less.

*AN EXAMPLE for you: A medium is known to have an index of refraction of 2.5, what is the speed of light in that medium.*

*Do this example and pass it in to your teacher with your lab write-up*

### 5- THEORY:

Optical fiber is made of two distinct layers of material. Light reflects at the boundary where the two layers meet. Light incident on that boundary has to conform to Snell's law to be guided. Guiding will take place if the condition for total internal reflection is satisfied.

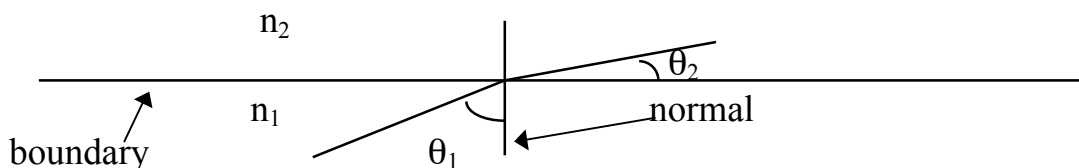

Snell's law states:  $n_1 \sin \theta_1 = n_2 \sin \theta_2$

The diagram below shows how light may or may not be guided

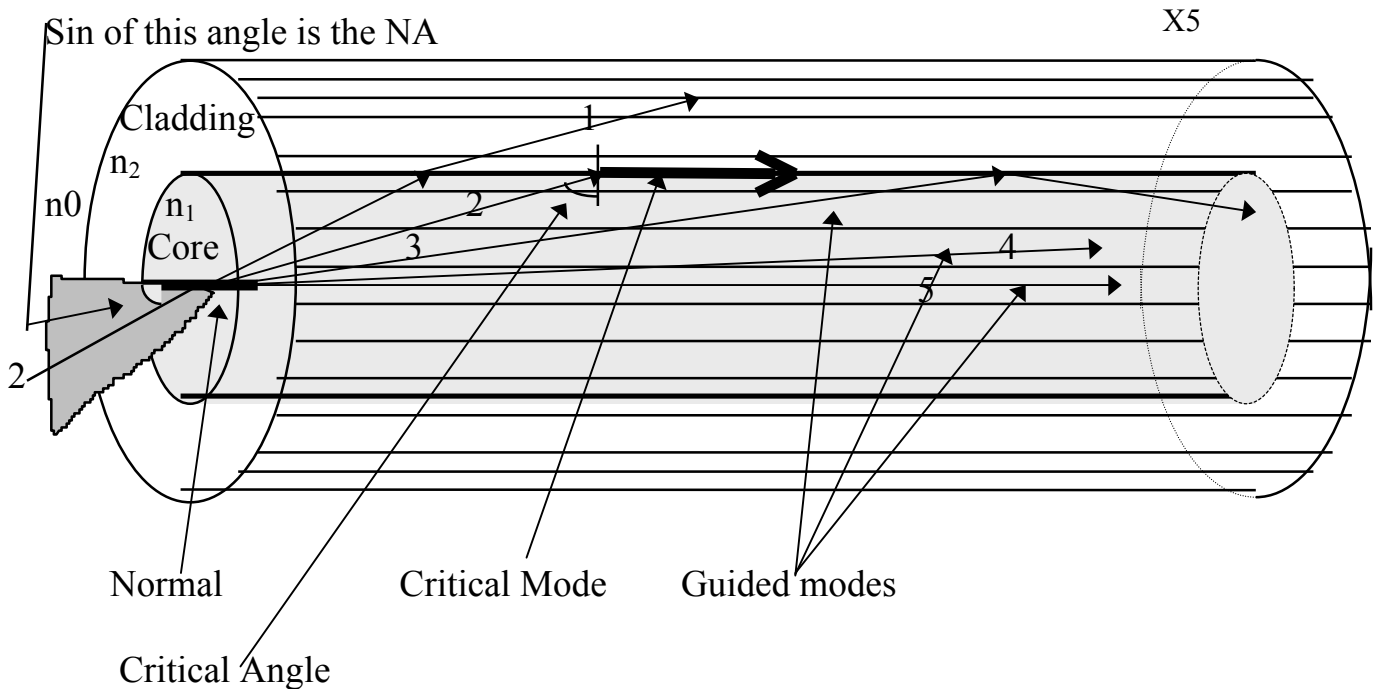

Look at ray # 1, this ray has failed to satisfy the conditions for the total internal reflection and it radiated into the cladding. This ray will soon be lost.

Look at ray # 3, this ray has satisfied the conditions for total internal reflection and it became guided in the core.

Look at ray # 2, this ray is in between. It is neither guided nor radiated. It is on the boundary, it is called the **Critical Mode**. Please observe the location of the **critical angle**

Look at the left hand side of the diagram, you can see where ray # 2 was originated. It would be of interest to us to measure, or calculate, the angle that ray makes with the normal. In this lab, we will measure this angle. The sin function of this angle is called the Numerical Aperture.

Mathematically, the NA is given by: 
$$\frac{\sqrt{n_1^2 - n_2^2}}{n_0}$$
 note  $n_0 = 1$  because we have the fiber in air



In practice, we do not know the values of  $n_1$  or  $n_2$  so we have to find NA by actually measuring it experimentally.

## 6- MATERIAL:

X5

Each group of 2 or 3 needs the following:

- several Terminated glass or plastic fiber optics cables
- 1 Optical power source and 1 optical power meter
- 1 Alignment and Rotary stage

## OVERVIEW:

- \* The class will work in groups of 2s and 3s
- \* Two best 1000um core short cable (1m long) will be selected by each group
- \* Two best 100um core cable will be selected by each group (if using that type of glass fiber)
- \* Two best 62.5um core cable will be selected by each group (if using that type of glass fiber)

## 7- PROCEDURE:

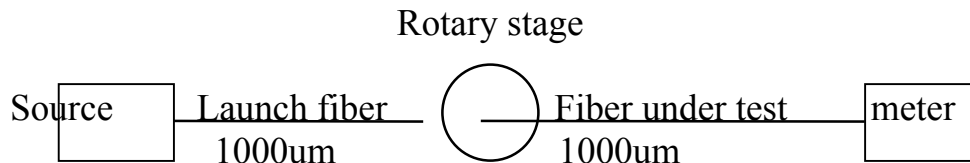

1- Connect as shown and:

2- **Align** the two fibers along all axis (XYZ) so as to **maximize** the reading on the power meter

3- **Bring** the two fibers as close together as possible but without touching

4- **Rotate** the rotary stage to one extreme and be sure (by watching) that the two ferrules of the two connectors do not touch. They should be as close as possible but not touch.

5- Now, **rotate** the rotary stage to the opposite direction in one (or two) degrees increments. Record the reading on the power meter for every angle

X5

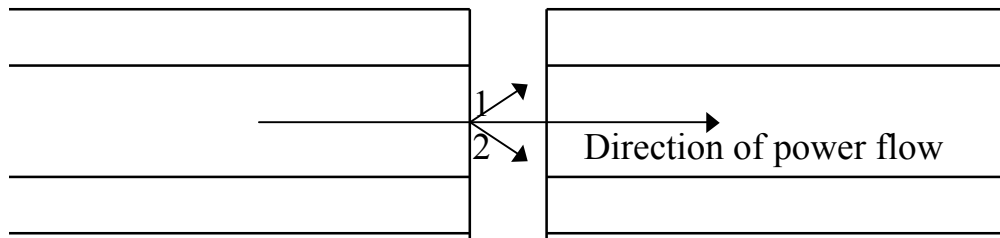

Under this condition, the launch and receive fibers are aligned and maximum power will transfer from the launch to the receive fiber.

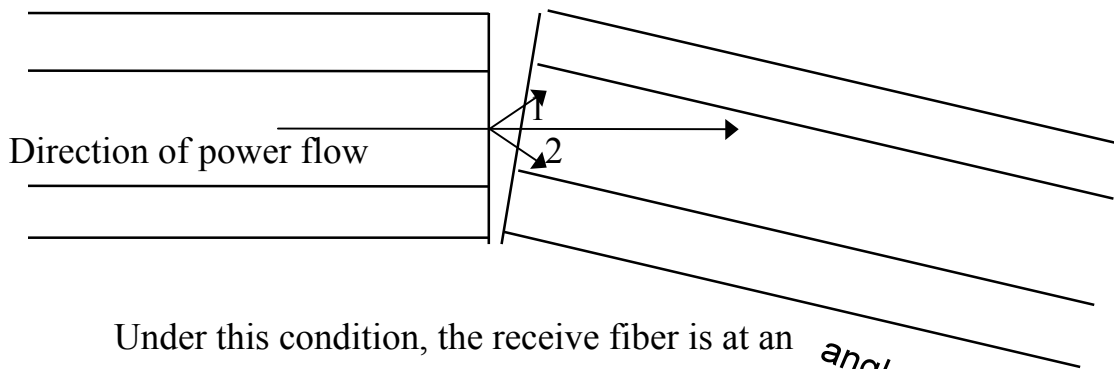

Under this condition, the receive fiber is at an *angle to the launch fiber*

And as you can see, ray #1 will never get to be guided inside the receive fiber. This means the total optic power available in the receive fiber is reduced.

As you continue to rotate one fiber with respect to the other, the power in the receive fiber will continue to drop. This happens because light rays between rays 1 and 2 start to drop off one after another (starting from the side of ray 1) thus causing overall power drop in the receive fiber.

6- Record the power level exiting from the receive fiber for every 2° increment in the rotary stage. Eventually, you will plot these values.

As you may see, to maximize the accuracy of this measurement, it would be best to have the receive fiber work with a collimated beam of light instead of a diverging beam as shown.

If your power meter reads in dBm, you have to convert these readings to the mW domain

7- Complete the tables below:

X5

1000um launch fiber, 1000um receive fiber

angle	Power in dBm	Power in mW
-55°		
0°		
+55°		

complete the table below  
using 2 degree increments

1000um launch fiber, 100um receive fiber

angle	Power in dBm	Power in mW
-55°		
0°		
+55°		

1000um launch fiber, 62.5um receive fiber

angle	Power in dBm	Power in mW
-55°		
0°		

+55°

8- Plot the data from the tables above placing the angle on the X axis and the power on the Y axis. Do that for the power in mW and in dBm. Read the NA for each fiber from the mW graphs

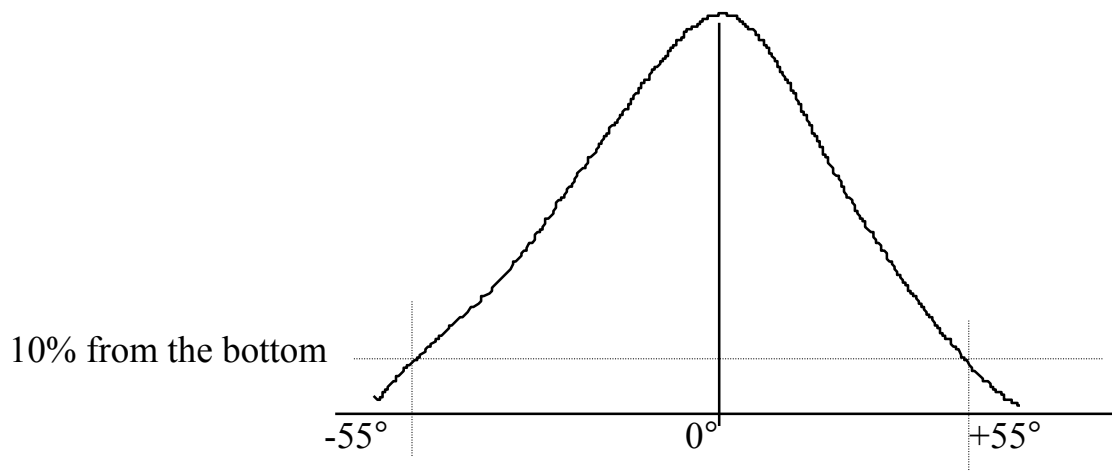

Your graphs should look something like this. In some cases, they could be off center.

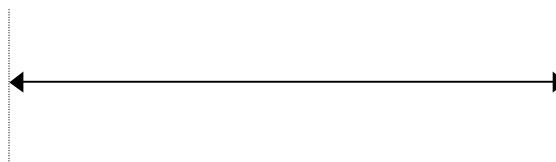

9- Read the angle between the two vertical lines, divide it by 2, take the sin of that angle. This is the Numerical Aperture of that fiber.

Do that for each of the fibers you have tested.

### 8- CALCULATION:

In this lab experiment, you are required to measure the power at the output of the receive fiber for every 2° of rotation. If you plot the values, you will have a bell X5 shape distribution with respect to the angle.

It is important to plot the data accurately to increase the accuracy of your readings from the graph. Read the angle at the 90% point from-the-top by projecting the points of intercept on the X axis. This angle represents rotation to either side from the zero. As you know by now, **NA is measured to one side of the zero** (on one side of the normal). This means you have to divide that angle by 2 and calculate the sine of that half. This is the NA of your fiber.

Example calculation:

X5

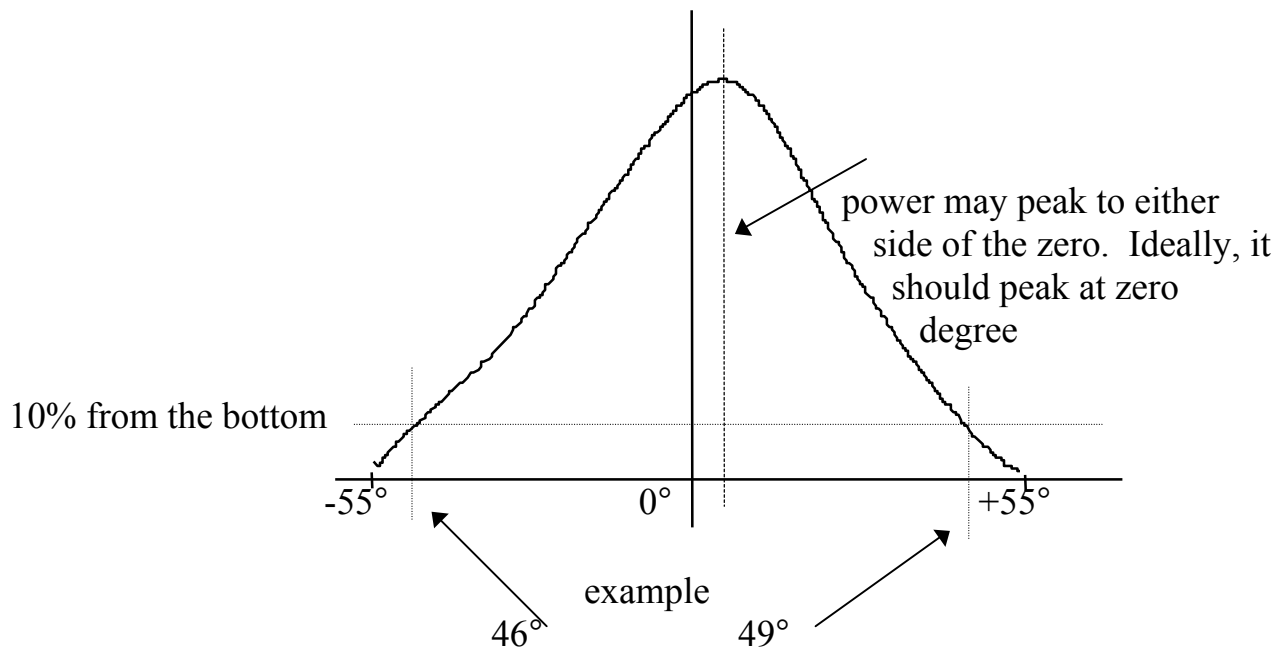

Total angle swing =  $46^\circ + 49^\circ = 95^\circ$  ,  $95^\circ$  divide by 2 =  $47.5^\circ$

$\text{Sin } 47.5^\circ = .737 = \text{NA}$  for this fiber

Please note that this is too high a value for NA. Typical communication fiber would

have NA of about 0.2 or so, that is it accepts light at an angle of  $\sin^{-1} 0.2$   
 = \_\_\_\_\_ deg

### 9- RESULTS:

Typically, the results of a laboratory exercise gives the student the opportunity to contrast the actual outcome to the anticipated outcome quantitatively. This does not apply in this exercise unless you have access to the manufacturer's data sheet for this fiber. If you do, compare and comment on the measured value of NA to that specified by the manufacturer.

### 10- DISCUSSION:

X5

Student: Please write a short discussion. Describe, in your own words, how you would re-write this lab, if you had to. What you would change in it and why. What advise would you give to someone intending to do what you had just finished.

### 11- CONCLUSION:

Students: Please write a conclusion about this exercise. Contrast what was intended to what was accomplished. Explain the reason(s) for any differences between the two. In addition, offer recommendation(s) on how to make the outcome coincide with the objective. Do that so others doing this exercise will be able to make use of your recommendations and observations to achieve better match between the objective and conclusion.

# Lab Exercise 6

## 1- TITLE:

Measuring the end separation loss of your plastic optical fiber

## 2- OBJECTIVE:

This is a laboratory experiment. We are planning to develop your understanding of the testing methodology and the testing and calculation procedure relating to the end separation of two fibers. Fiber separation may occur in several ways. In this experiment, we will study the case where the two fibers ends are not touching. And we will study the case where that separation is increasing.

The significance of this study is to develop a graphical representation of the loss as a function of separation. **Such information can be used to develop a calibrated sensor such as a proximity or level sensor.**

## 3- PURPOSE:

It is the responsibility of the operator to ensure that two joining fibers are flat and smooth. This will ensure that the touching surfaces are in full contact and with virtually no air gap in between, not even a thin air gap. Sometimes, the operator places a liquid gel between the two fibers to fill out (and thus remove) any air gap. Technically, this works. However, practically, we have to be concerned with the dust gathering ability of the matching gel and the drying of it over time.

When connecting two fibers, it is most likely you want them to be in full contact and maximize power transfer between the two. Only when you are doing sensor application, you may want to introduce an air gap to make the setup sensitive to displacement.

So air gap may be good in sensor application and optical attenuators but it must be eliminated, or reduced significantly, in communication applications.

## 4- TUTORIAL:

When two fibers are aligned, optic power transfer will be maximized between these two fibers. To ensure maximum power transfer, the surface of the two fibers must be flat, smooth, clean and in full contact.

Early fiber optic connectors were designed to maintain an air gap between the two fibers. Although the air gap introduced additional loss, it had to be tolerated. The air gap was intended to prevent the two fibers from touching. Early connectors had no mechanisms to prevent them from **rolling** about their axis, **rubbing** and **scratching** the surfaces of the fiber.

Today, all fiber optic connectors are keyed. The keying prevent the connectors from rolling about their axis. This ensures that the surfaces of the fibers have no opportunity to scratch each other even when they are touching.

Some manufacturers have designed and are selling devices that introduces deliberate air gap between two fibers. Infact, the up scale models of such devices make that air gap adjustable. The purpose of the air gap is to introduce loss into an optical link to simulate losses that may develop in long runs.

So as you can see, on one hand, air gaps can be detrimental to the performance of an optical link. They cause additional loss of the optical power and increase the need for amplifiers. And on the other hand, air gaps can be utilized to simulate system performance and test system characteristics. Also, air gaps can be used to sense motion, or the separation, of objects.

### 5- THEORY:

The reason for optical power loss induced by the separation of two fibers is intuitively obvious. As you can see in the illustration below, the two fibers are separated a distance  $X$  , the light leaving the transmit fiber, travels at an **angle** forming a cone between the two fibers.



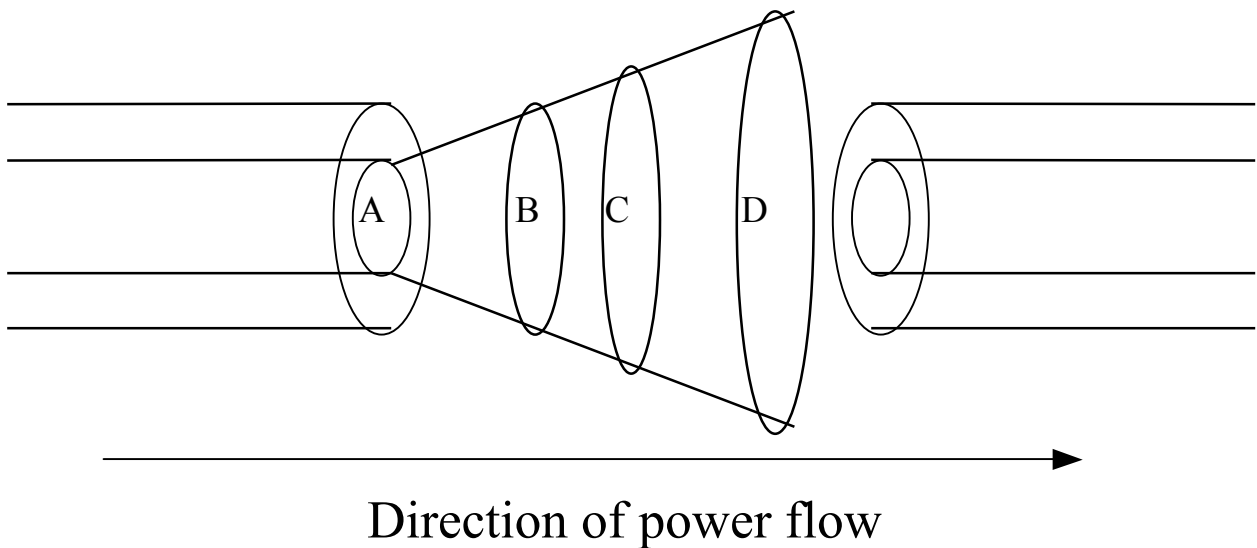

The optic power leaving the transmit fiber on the left is proportional, among other things, to the cross section area “A” of the core of the transmitting fiber. All others being constant, the total optic power present in the planar surface “A” is equal to the total optic power present in the planar surface “B” is also equal to the total optic power present in the planar surface “C” and is equal to the total optic power present in the planar surface “D” .

While the optic powers are equal at each of the “A”, “B” , “C” and “D” surfaces, the area of each of these surfaces is not equal. Students can see that the “**power density**” on these surfaces drops as the area of the surface increases. In this case, the area increases as the separation between the two fibers is increased.

One can rush to the conclusion that the loss between two fibers separated distance  $X$  is a function of that distance  $X$ . In fact, there is yet another variable in this equation.

Not only the surface area of the plane between the two fibers increase as a function of the distance between the two fibers, but also it increases as a function of the angle at which the light leaves the fiber. As you may recall, that angle defines the fiber’s Numerical Aperture, NA

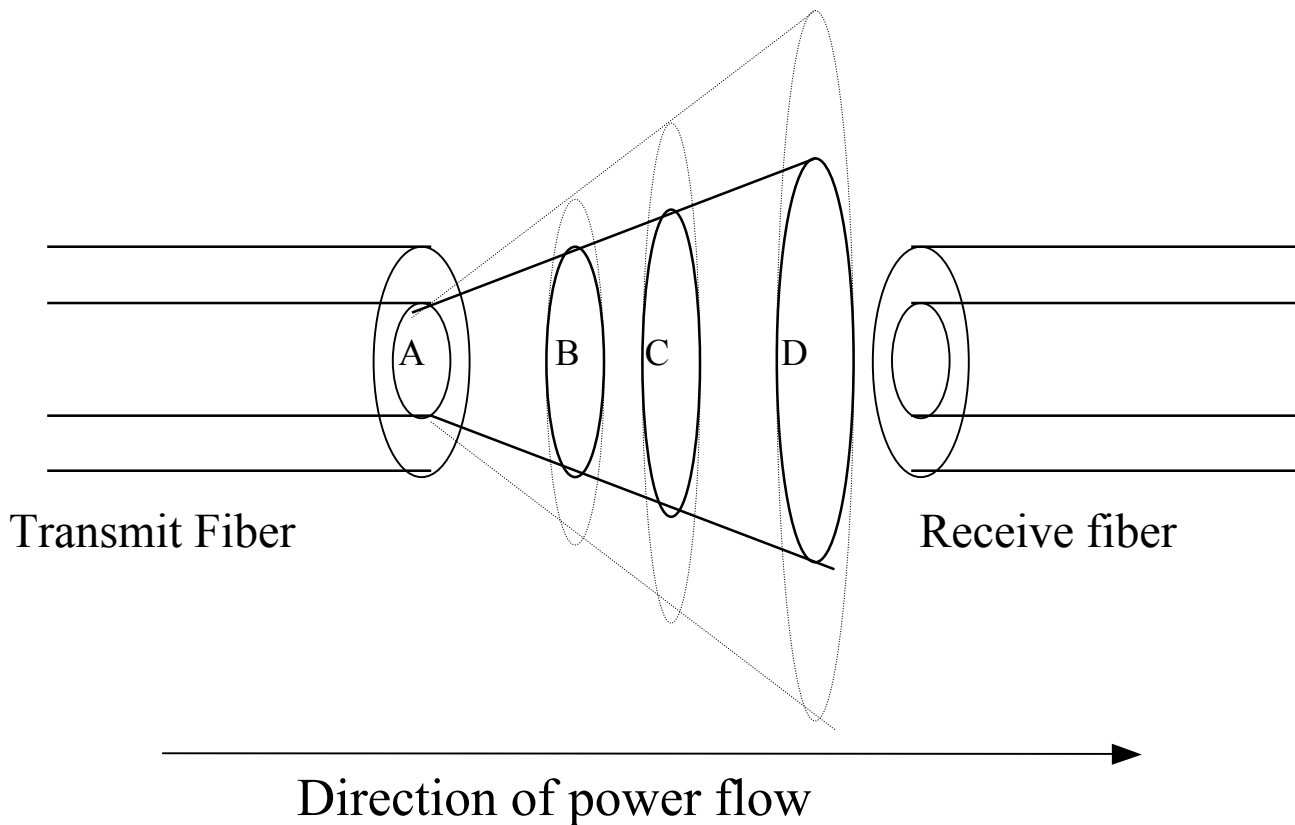

The diagram above illustrates the idea that the Angle at which the light leaves the transmitting fiber, related to the fiber's NA, has a direct effect on the surface area of each of the "B", "C" and "D" planes. This in turn, has a direct effect on the optic power density available for coupling into the receive fiber.

In its simplest form, the optic power coupled into the receive fiber is related directly to the ratio of the surface area of the core of the receive fiber to the cross section of the plane "A", "B", "C", "D" or any other plane in between.

In this laboratory experiment, we will develop data related to the actual power loss, analyze it and plot it with respect to distance of separation.

## 6- MATERIAL:

Each group of 2 or 3 needs the following:

- several Terminated glass or plastic fiber optic cables preferably with different core diameter and different NA
- 1 Optical power source and 1 optical power meter
- 1 Alignment and Rotary stage

## OVERVIEW:

- \* The class will work in groups of 2s and 3s
- \* Two best 1000um core short cable (1m long) will be selected by each group
- \* Two best 100um core cable will be selected by each group (if available)
- \* Two best 62.5um core cable will be selected by each group (if available)
- \* We will measure the separation loss of the fibers using different core and NA combination (if available)

## 7- PROCEDURE:

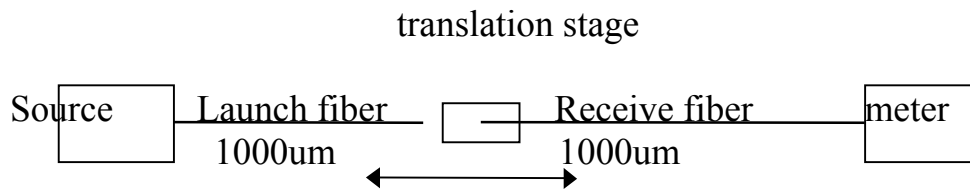

**Start** with the 1000um fiber on the launch and receive ends.

**Bring** the two fibers as close together as possible but without touching. Bring them as close as the thickness of a thin sheet of paper.

**Align** the two fibers along all axis so as to **maximize** the reading on the power meter

**Separate** the two fibers along their longitudinal axis by about 30 to 50 micrometer increments. Record the total separation and power reading in dBm and mW.

If your power meter reads in dBm, you have to convert these readings to the mW domain

Complete the tables below:

1000um launch fiber, 1000um receive fiber

Separation	Power in dBm	Power in mW
0		

translation stage

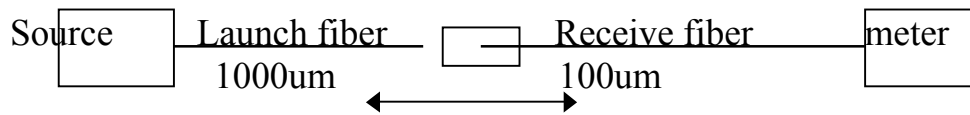

1000um launch fiber, 100um receive fiber

Separation	Power in dBm	Power in mW
0		

translation stage

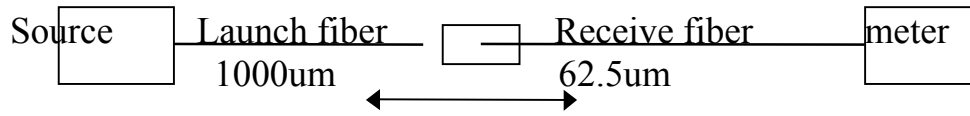

1000um launch fiber, 62.5um receive fiber

Separation	Power in dBm	Power in mW
0		

translation stage

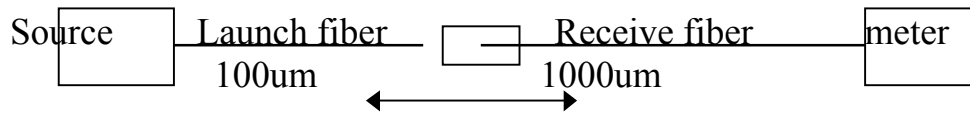

100um launch fiber, 1000um receive fiber

Separation	Power in dBm	Power in mW
0		

translation stage

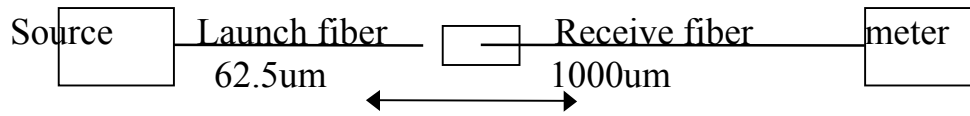

62.5um launch fiber, 1000um receive fiber

Separation	Power in dBm	Power in mW
0		

translation stage

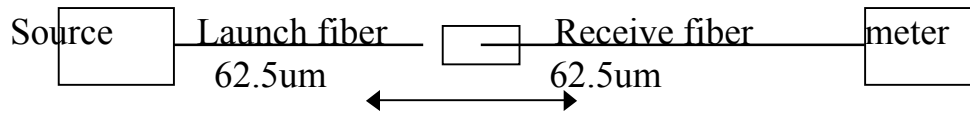

62.5um launch fiber, 62.5um receive fiber

Separation	Power in dBm	Power in mW
0		

Plot the data above using the separation on the X axis and the power loss on the Y axis. Do that for the power in mW and in dBm. Observe the data, the rate at which the power drops as a function of the combination of fibers and direction of power transfer



Your graphs should look something like this.

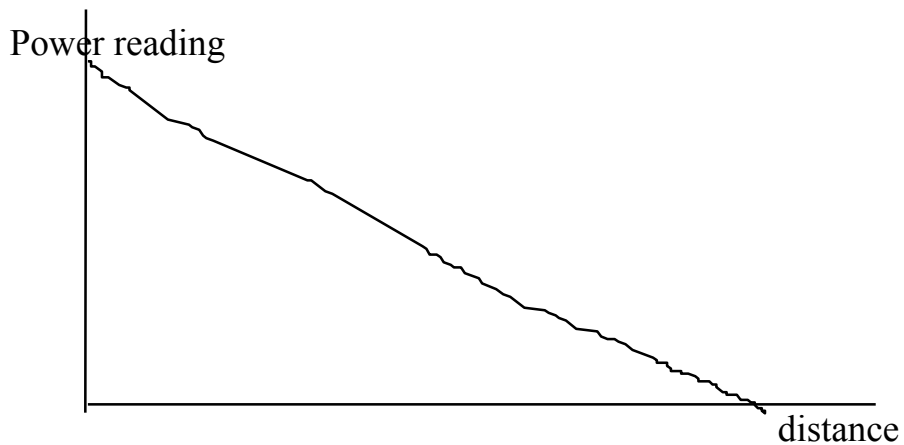

Students: Please note the difference in the **shape** of the curve when using dBm and using mW

Do that for each of the fibers you have tested. Make a final comment on the most and least penalizing combination of fibers and direction of power flow.

## 8- CALCULATION:

In this lab experiment, you are required to measure the power at the output of the receive fiber for every 30 to 50 micrometer increment. If you plot the values, you will have a graphical representation of the loss as a function of separation. You can select points on your graph to predict the power loss for various separations

It is important to plot the data accurately to increase the accuracy of your readings from the graph.

Example calculation:

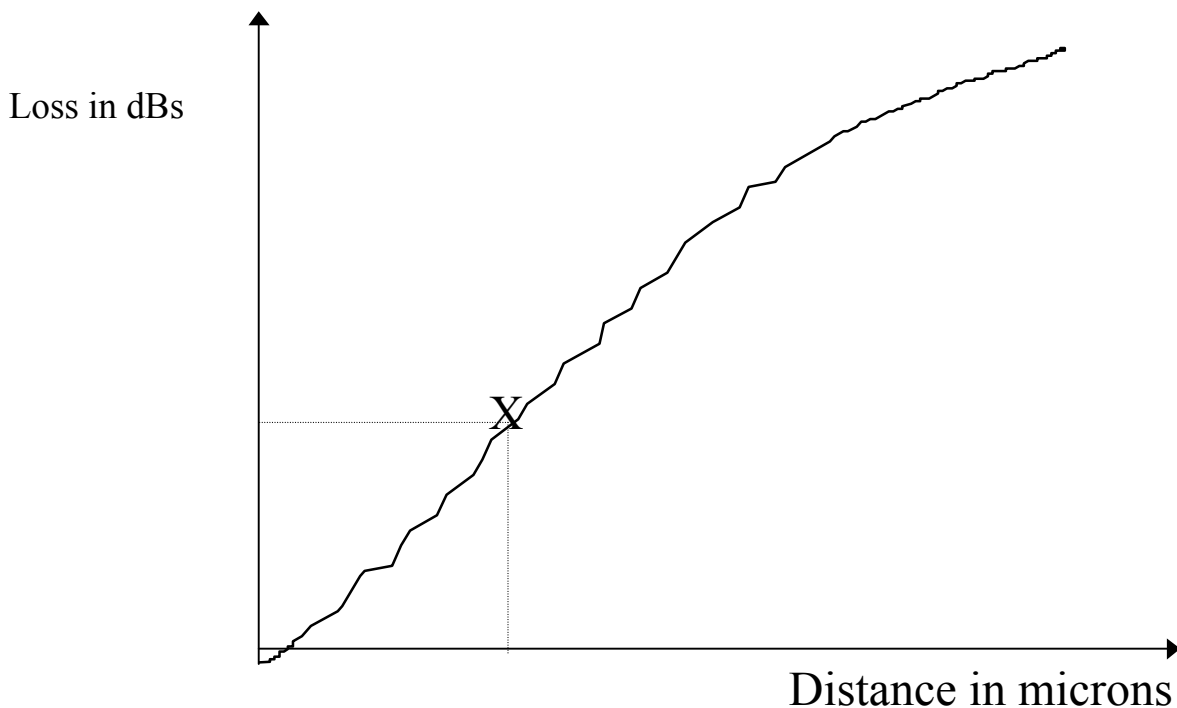

Using a calibrated scale on the graph paper, you can read the X and Y intercept of any point on the graph. Here, you have the ability to project the loss of optical power at any point on the graph. If your school have the resources, and if you have collected data for more than one fiber, you are required to generate a graph for each of the sets of data you have.



## 9- RESULTS:

Typically, the results of a laboratory exercise gives the student the opportunity to contrast the actual outcome to the anticipated outcome quantitatively. This does not apply in this exercise unless you have access to the manufacturer's data sheet for this fiber.

Alternatively, if you have access to the equation to predict power loss as a function of separation, you should compare the calculated value to the values from the graph. On the other hand, if you do not have that equation, research it in the library and your reference texts. This would be your homework for this lab.

Once you found the equation, to calculate the theoretical power loss, you need to know the Numerical Aperture of the fiber. Alternatively, you can use the measured NA you obtained from a previous laboratory experiment.

## 10- DISCUSSION:

Student: Please write a short discussion. Describe, in your own words, how you would re-write this lab, if you had to. What you would change in it and why. What advise would you give to someone intending to do what you had just finished.

## 11- CONCLUSION:

Students: Please write a conclusion about this exercise. Contrast what was intended to what was accomplished. Explain the reason(s) for any differences between the two. In addition, offer recommendation(s) on how to make the outcome coincide with the objective. Do that so others doing this exercise will be able to make use of your recommendations and observations to achieve better match between the objective and conclusion.

# Lab Exercise 7

## 1- TITLE:

Measuring the Axial separation loss of your plastic optical fiber

## 2- OBJECTIVE:

This is a laboratory experiment. We are planning to develop your understanding of the testing methodology and the testing and calculation procedure relating to the separation of two fibers. Fiber separation may occur in several ways. In this experiment, we will study the case where the two fibers ends are separated axially.

The significance of this study is to develop a graphical representation of the loss as a function of axial separation. Such information can be used to develop a calibrated sensor such as a pressure or displacement sensor.

## 3- PURPOSE:

It is the responsibility of the operator to ensure that two joining fibers are flat, smooth and in perfect alignment, or at least as close to perfect alignment as possible. This will ensure that the touching surfaces are in full contact and with virtually no, or insignificant, power loss. If the fibers are axially displaced, the placement of index matching gel will not fix the problem. As you recall from the previous experiment, liquid gel can be added to fill out the air gap and fix the problem of end separation. In the case being analyzed here, only perfecting the mechanical alignment will reduce the penalty of power loss associated with axial misalignment.

When connecting two fibers, most likely you want them to be in full contact and best alignment to maximize power transfer between the two. Only when you are doing sensor application, you may want to introduce any type of displacement to make the setup sensitive to that displacement.

So axial displacement is undesired in fiber optic links intended for communication. on the other hand, we may want to introduce, or allow, axial displacement to measure

physical variables such as pressure or temperature variations, which may cause some kind of displacement.

**4- TUTORIAL:**

When two fibers are aligned, optic power transfer will be maximized between these two fibers. To ensure maximum power transfer, the surface of the two fibers must be flat, smooth, clean and in full contact.

Let me add this. Lately, technology allows us to make pre-domed connectors. These connectors allow the end surface of the fiber to be rounded in the same curvature as the tip of the pre-domed connector. In this case, when you bring the two fibers together, the core of the fibers touch first. See the illustrations below:

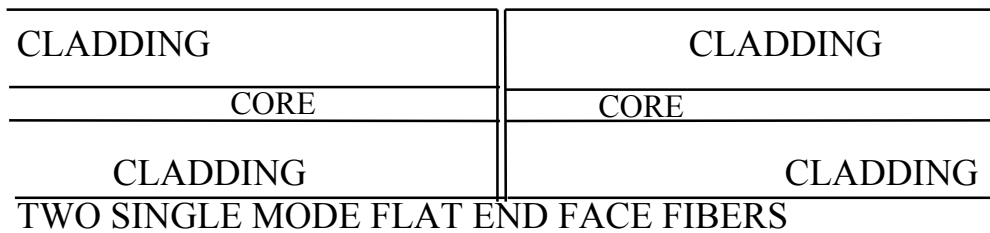
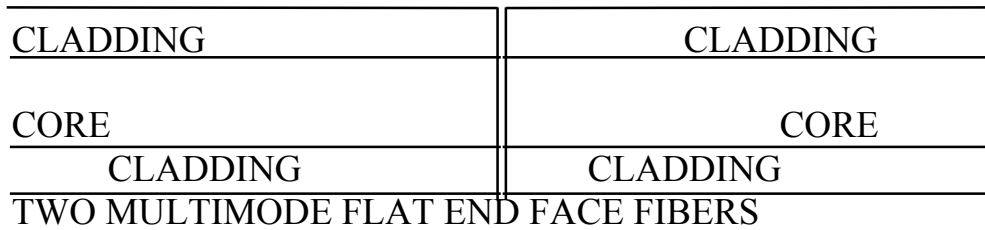

**Note:** in both cases above, surface irregularity in the cladding and the connector (the connector is not shown in this illustration) will reduce the certainty of core contact.

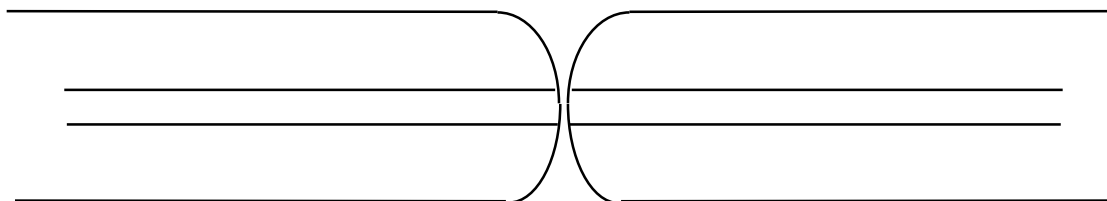

TWO SINGLE MODE FIBERS WITH ROUNDED END FACE. NOTE, IN THIS CASE, THE TWO CORES WILL HAVE A “MORE CERTAIN” CONTACT. TYPICAL RADIUS OF CURVATURE IS ABOUT 2.5 CM

All fiber optic connectors were designed to maintain accurate mechanical alignment between the two fibers. There are three different ways in which we connect two fibers.

1- by mechanical means which may involves mechanical and screw arrangement.

2- by mechanical alignment inside a narrow cavity

3-by fusion of the two fibers. This involves the melting of the two fibers together.

In each one of these mechanisms, the possibility of the two fibers being out of alignment is a serious matter. In the case of fusion splicing, the fibers have to be broken and re-spliced. In the case of mechanical splicing, the splice will have to be exchanged for a higher quality brand. Finally, in the case of a mechanical connector, the technician will have to select better connectors or better alignment sleeves or a combination of both.

In a low quality connector, the hole in the front ferrule of the connector may be off center. Another possibility, the hole may be larger than necessary which may allow the fiber to shift to one side of the connector. When mated with the fiber in another connector, the two fibers will exhibit axial misalignment with respect to each other.

So as you can see, under no circumstances we want to have two fibers with axial misalignment unless we are trying to use that setup for sensing displacement. This is a very high loss problem and must be eliminated or minimized at every reasonable cost.

### 5- THEORY:

The reason for optical power loss by the axial separation of two fibers is intuitively obvious. As you can see in the illustration below, the two fibers are separated a distance “d” which leaves them a common surface area outlined in the cross hatched over lapping areas of the cores. Much of the light leaving the transmit fiber will not find its way to the core of the receive fiber because the two cores do not line up, they are **axially** mis-aligned.

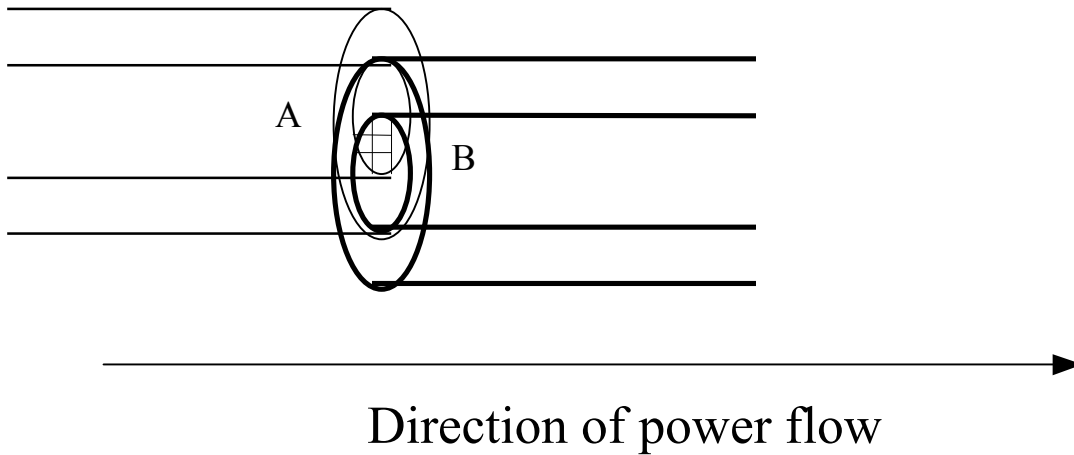

The optic power leaving the transmit fiber on the left is proportional, among other things, to the common cross section area of the overlapping cores. All others being constant, the total optic power present at the output of the “A” fiber, should, under best conditions, be coupled into the receive fiber “B”

The axial misalignment depicted above was represented in experiment 3 as shown below. This is the representation of two overlapping circles with a common surface area..

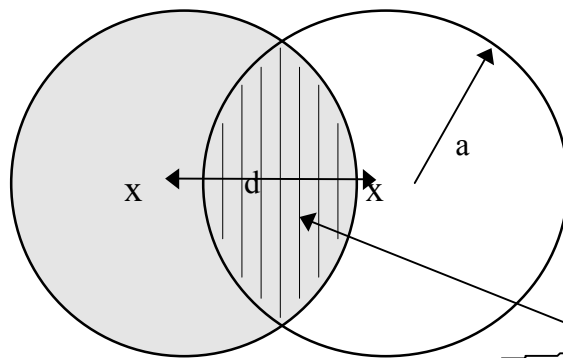

TWO OVERLAPPING FIBERS WITH THE COMMON SURFACE AREA  $A_c$  IN THE MIDDLE.

In step index fiber, which this is, the optic power loss is a function of the coupling efficiency. The coupling efficiency is the ratio of the core surface area “A” divided by the common surface area “ $A_c$ ”

$$A = \pi a^2$$

$$A_c = 2a^2 \cos^{-1} d/2a - d \sqrt{a^2 - (d^2/4)}$$

In this laboratory experiment, we will develop data related to the actual power loss, analyze it and plot it with respect to distance of separation.

### 6- MATERIAL:

Each group of 2 or 3 needs the following:

- several Terminated glass and plastic fiber optic cables with different core diameter and different NA
- 1 Optical power source and 1 optical power meter
- 1 Alignment and Rotary stage. **Note:** if you are using glass fiber with a small core diameter, you may need at least 2um resolution in the alignment apparatus

### OVERVIEW:

- \* The class will work in groups of 2s and 3s
- \* Two best 1000um core short cable (1m long) will be selected by each group
- \* Two best 100um core cable will be selected by each group
- \* Two best 62.5um core cable will be selected by each group
- \* We will measure the separation loss of the fibers using similar core and NA combination

PROCEDURE:

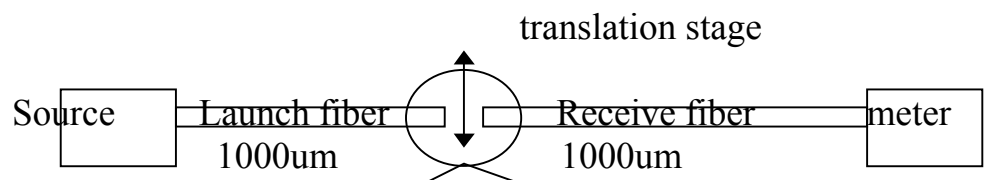

**Displace the two cores axially as shown in the sequence below.**

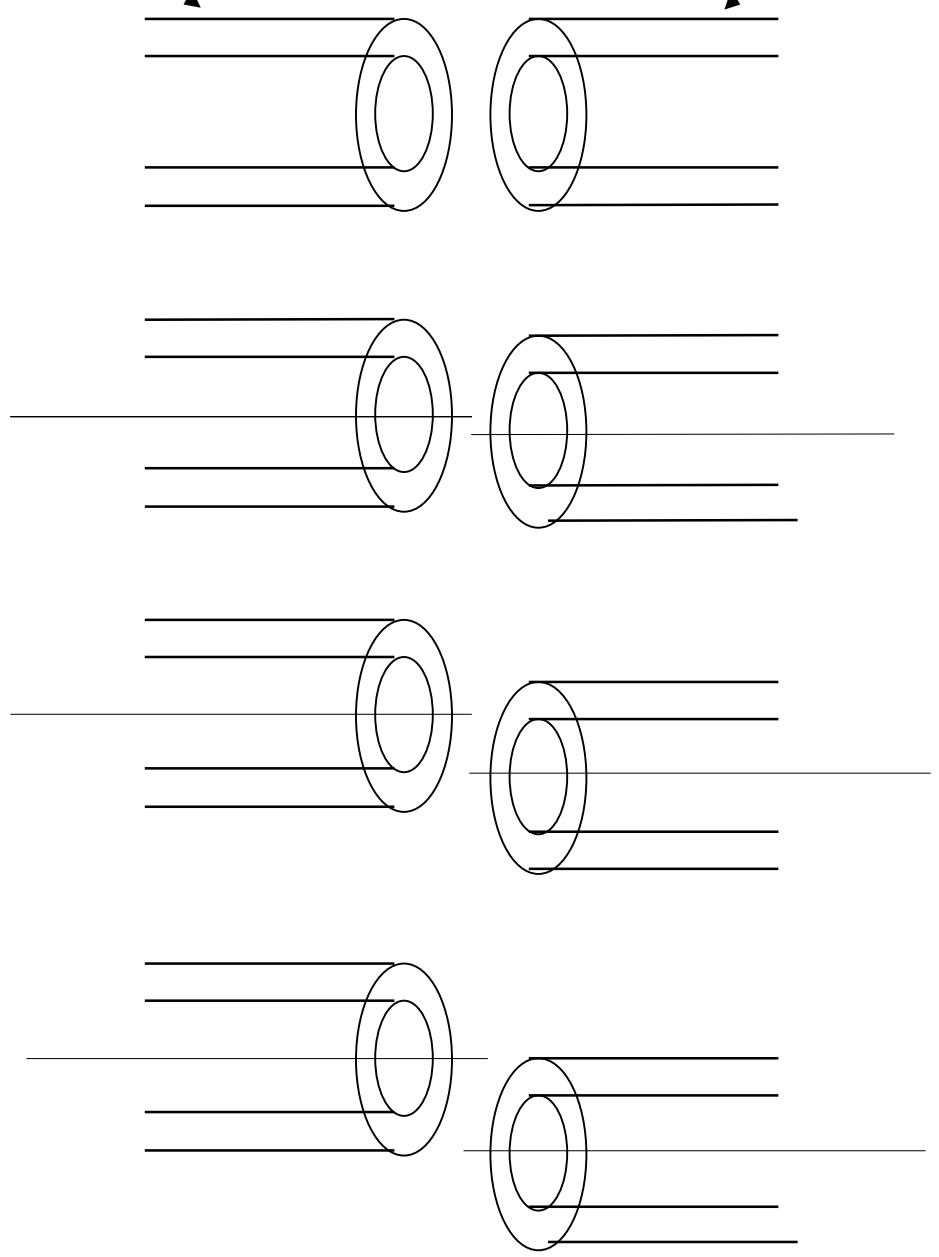

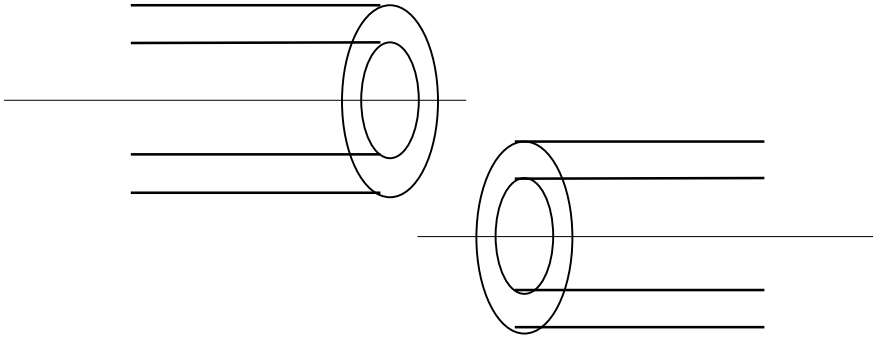

**Start** with the 1000um fiber on the launch and receive ends.

**Bring** the two fibers as close together as possible but without touching. Bring them as close as a thin sheet of paper.

**Align** the two fibers along all axis so as to **maximize** the reading on the power meter

**Separate** the two fibers axially as shown in the sequence above 20 micrometer increments. Record the total separation and power reading in dBm and mW.

If your power meter reads in dBm, you have to convert these readings to the mW domain

Complete the tables below:

NOTE: 20 um increments in a 1000um fiber will produce 50 points of data. If time does not allow you that, do 50 um increments instead.

1000um launch fiber, 1000um receive fiber

Separation	Power in dBm	Power in mW
0		
50		
100		
150		
200		
250		
300		
350		



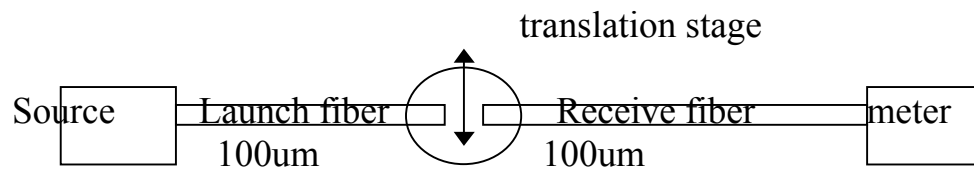

X7

**Displace the two cores axially as shown in the sequence above**

In a 100 um fiber, 50 um increments will produce only 2 points of data. Here, take data in 10um increments

100um launch fiber, 100um receive fiber

Separation	Power in dBm	Power in mW
0		
10		
20		
30		
40		
50		
60		
70		
80		
90		
100		

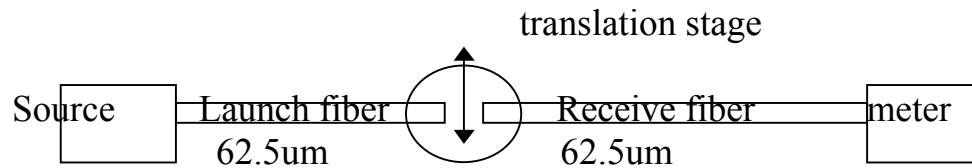

X7

**Displace the two cores axially as shown in the sequence above**

The apparatus you are using allows you 1 $\mu$ m increments. You will need this kind of resolution when using single mode fiber. In 62.5 $\mu$ m fiber, you should take reading every 5 $\mu$ m

62.5 $\mu$ m launch fiber, 62.5 $\mu$ m receive fiber

Separation	Power in dBm	Power in mW
0		
5		
10		
15		
20		
25		
30		
35		
40		
45		
50		
55		
60		

Plot the data above using the separation on the X axis and the power on the Y axis. Do that for the power in mW and in dBm. Observe the data, the rate at which the power drops as a function of the fiber core diameter.

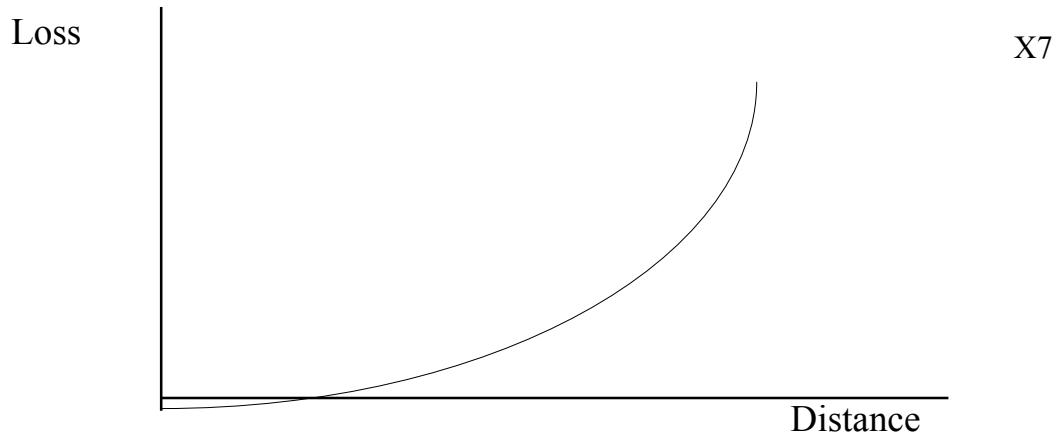

One of your graphs should look something like this. Note the units of the loss in this graph (is it dBs or mW??) and in the other graph which is not provided.

Do that for each of the fibers you have tested. Make a final comment on the most and least critical fiber when it comes to axial misalignment.

### 8- CALCULATION:

In this lab experiment, you are required to measure the power at the output of the receive fiber for every 6 to 50 micrometer increment depending on the size of the fiber you are using (that is if you are using more than one fiber). If you plot the values, you will have a graphical representation of the loss as a function of axial separation. You can select points on your graph to predict the power loss for various separations

It is important to plot the data accurately to increase the accuracy of your readings from the graph.

Example calculation:

X7

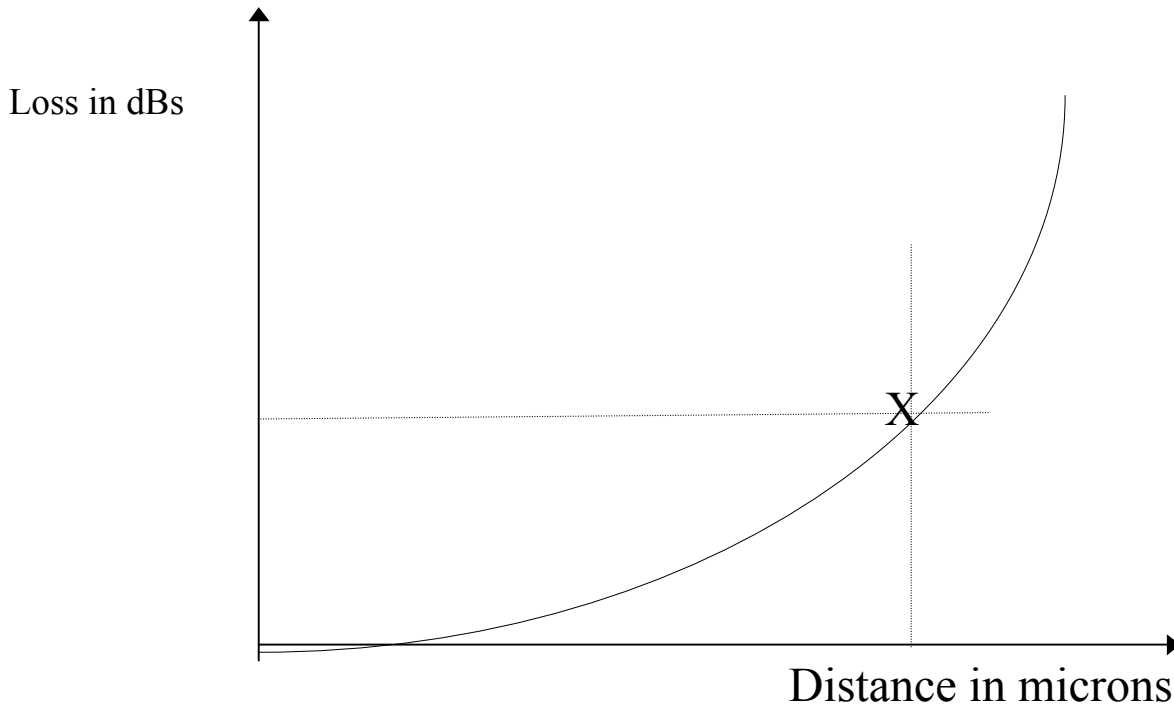

Using a calibrated scale on the graph paper, you can read the X and Y intercept of any point on the graph. Here, you have the ability to project the loss of optical power at any point on the graph. If your school have the resources, and if you have collected data for more than one fiber, you are required to generate a graph for each of the sets of data you have.

### 9- RESULTS:

Typically, the results of a laboratory exercise gives the student the opportunity to contrast the actual outcome to the anticipated outcome quantitatively. This does apply in this exercise unless you have access to the manufacturer's data sheet for this fiber.

Alternatively, if you have access to the equation to predict power loss as a function of separation, ( in this case you have it) you should compare the calculated value to the values from the graph.

To calculate the theoretical power loss, you need to know the Numerical Aperture of the fiber. Alternatively, you can use the measured NA you obtained from a previous laboratory experiment.

X7

### 10- DISCUSSION:

Student: Please write a short discussion. Describe, in your own words, how you would re-write this lab, if you had to. What you would change in it and why. What advise would you give to someone intending to do what you had just finished.

### 11- CONCLUSION:

Students: Please write a conclusion about this exercise. Contrast what was intended to what was accomplished. Explain the reason(s) for any differences between the two. In addition, offer recommendation(s) on how to make the outcome coincide with the objective. Do that so others doing this exercise will be able to make use of your recommendations and observations to achieve better match between the objective and conclusion.

# Lab Exercise 8

## 1- TITLE:

Measuring the Angular misalignment loss of your plastic optical fiber

## 2- OBJECTIVE:

This is a laboratory experiment. We are planning to develop your understanding of the testing methodology and the testing and calculation procedure relating to the separation of two fibers. Fiber separation may occur in several ways. In this experiment, we will study the case where one or both fibers ends are at an angle to their axis.

The significance of this study is to develop a graphical representation of the loss as a function of angular misalignment. Such information can be used to develop a calibrated sensor such as a rotational sensor.

## 3- PURPOSE:

It is the responsibility of the operator to ensure that two joining fibers are flat, smooth and in perfect alignment, or at least as close to a perfect alignment as possible. This will ensure that the touching surfaces are in full contact and with virtually no, or insignificant power loss. If the fibers end faces are not at  $90^\circ$  to their axis, or if one of the fibers is rotated a few degrees with respect to the axis of the other fiber, optical power will suffer loss in the process of moving from one fiber to the next.

When cutting or polishing or aligning two fibers, you want them square with their own axis and each with the axis of the other fiber. All others being constant, this will maximize power transfer between the two. Only when you are doing sensor application, you may want to introduce any type of rotational displacement to make the setup sensitive to measure that particular physical parameter.

So Rotational displacement is undesired in fiber optic links intended for communication. on the other hand, we may want to introduce or allow rotational displacement to measure physical variables that may cause rotational displacement.

#### 4- TUTORIAL:

When two fibers are aligned, optic power transfer will be maximized between them . To ensure maximum power transfer, the surface of the two fibers must be flat, smooth, clean and in full contact.

All fiber optic connectors are designed to maintain accurate mechanical alignment between the two fibers. There are three different ways in which we connect two fibers.

1- by mechanical connectors which may involves mechanical screw arrangement.

2- by mechanical alignment inside a narrow cavity

3-by fusion of the two fibers. This involves the melting of the two fibers together.

In each one of these mechanisms, the possibility of the two fibers being out of alignment is a serious matter. In the case of fusion splicing, the fibers have to be broken and re-spliced. In the case of mechanical splicing, the splice will have to be exchanged for a higher quality brand. Finally, in the case of a mechanical connector, the technician will have to select better connectors or better alignment sleeves or a better polishing tools or a combination of all.

Rotational misalignment may be in one form or another or worst yet, a combination of both forms.

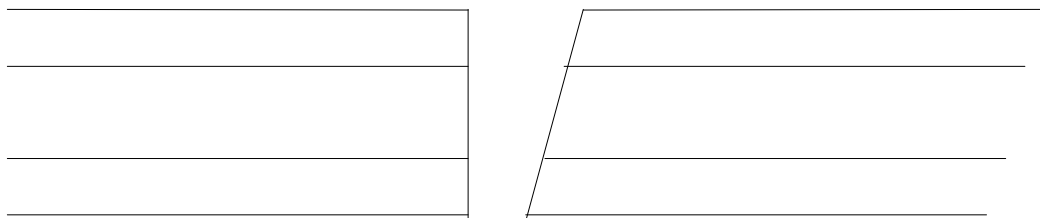

In this case, the fiber is cut at an angle, or the connector is polished at an angle

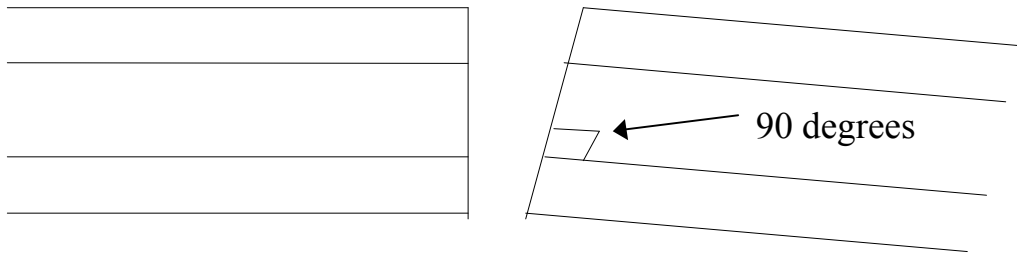

In this case, the fiber is not cut at an angle but one connector is installed at an angle with respect to the other connector.

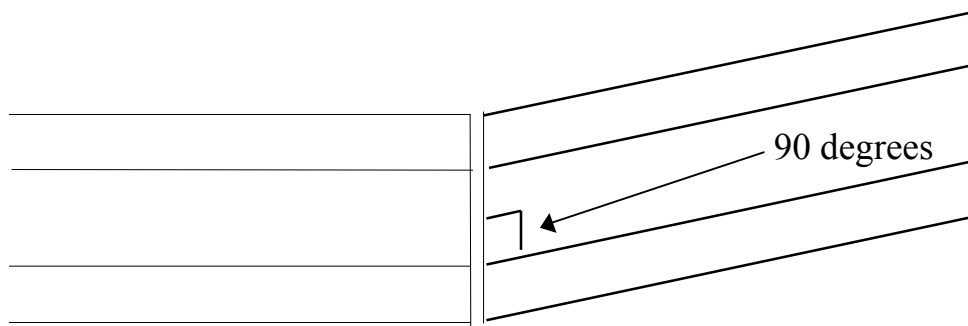

This is a representation of the case above after rotating one fiber a few degrees. If you think of it, you will see that the power meter will read higher power level after the fiber has incurred a few degrees of rotation. This may seem to contradict what you expect; which is power drop, not power rise, after a few degrees of rotation.

### 5- THEORY:

The reason optical power loss is induced by the rotational misalignment of two fibers is intuitively obvious. As you can see in the illustrations above, the two fiber ends are at an angle with respect to each other. This leaves them unsuitable to transmit or receive optical power from each other without significant loss.

The optic power leaving the transmit fiber on the left is doing so at an inherent angle consistent with the Numerical Aperture of that fiber. Since the transmit and receive fibers are of the same type, (this should always be the case) the receive fiber would



have an acceptance angle of the same value as the transmit fiber. Having either one of the two fibers at such a rotational angle with respect to its own axis or to the axis of the other fiber, we expect optic power will be lost.

This optic power loss between two angularly mis-aligned fibers is very costly in terms of the optic power.

Index matching gel may help some but it is not a suitable nor is it a final solution.

In step index fiber, which this is, the optic power loss is a function of the fiber Numerical Aperture, the cores diameters (we are assuming same size core) and the rotational angle between the two fibers.

In this laboratory experiment, we will develop data related to the actual power loss, analyze it and plot it with respect to the angle of rotation.

## 6- MATERIAL:

- Each group of 2 or 3 needs the following:
- several Terminated glass and plastic fiber optic cables with different core diameter and different NA
- 1 Optical power source and 1 optical power meter
- 1 Alignment and Rotary stage

## OVERVIEW:

- \* The class will work in groups of 2s and 3s
- \* Two best 1000um core short cable (1m long) will be selected by each group
- \* Two best 100um core cable will be selected by each group
- \* Two best 62.5um core cable will be selected by each group
- \* We will measure the angular misalignment loss of the fibers using similar core and NA combination

7- PROCEDURE:

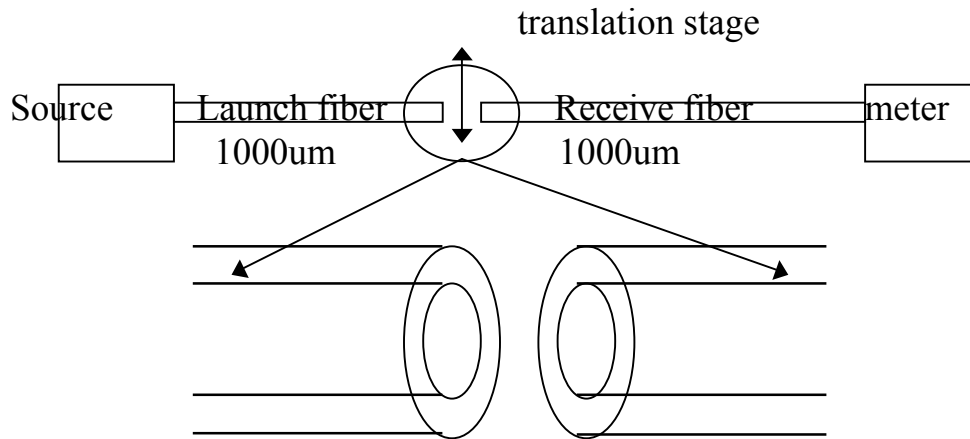

**Start with the fibers aligned. Adjust the XYZR variables on the testing apparatus so as to maximize the reading on the power meter  
Rotate one core angularly as shown below.**

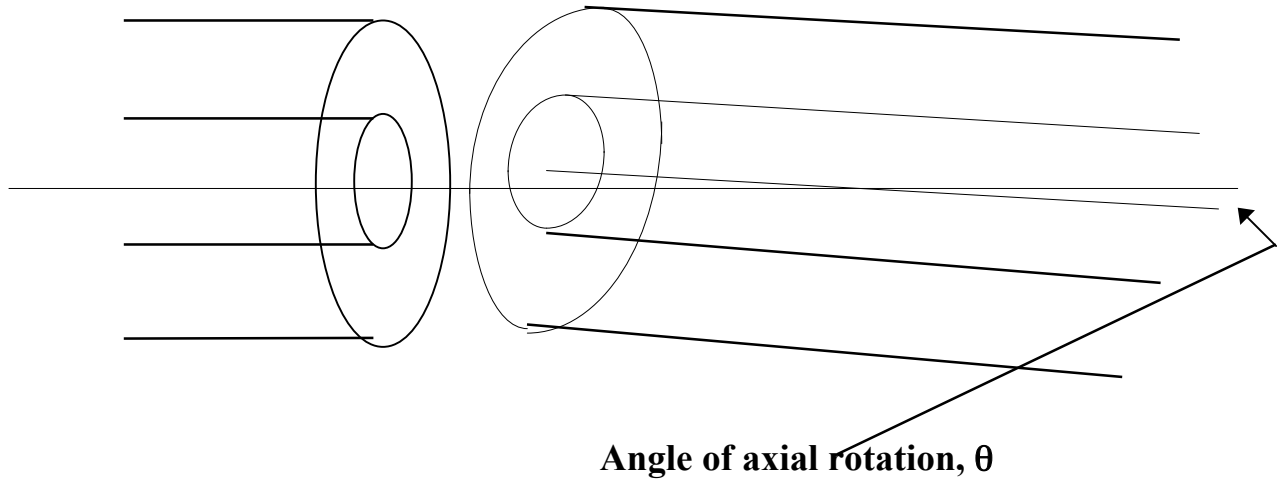

**Start** with the 1000um fiber on the launch and receive ends.

**Bring** the two fibers as close together as possible but without touching. Bring them as close as a thin sheet of paper. You may have to allow enough space between the two fibers to allow room for rotation depending on the connector size.

**Align** the two fibers along all axis so as to **maximize** the reading on the power meter

**Separate** the two fibers longitudinally to allow room for the rotating fiber to rotate the full range without interfering with the stationary fiber.

If your power meter reads in dBm, you have to convert these readings to the mW domain

Complete the tables below:

NOTE: 2° increments of rotation is easily achieved. A skilled operator can read 1 degree increments on the dial.

1000um launch fiber, 1000um receive fiber

Rotation	Power in dBm	Power in mW
2°		
4°		
6°		
8°		
10°		
12°		
14°		
16°		
18°		
20°		
.		
.		
.		

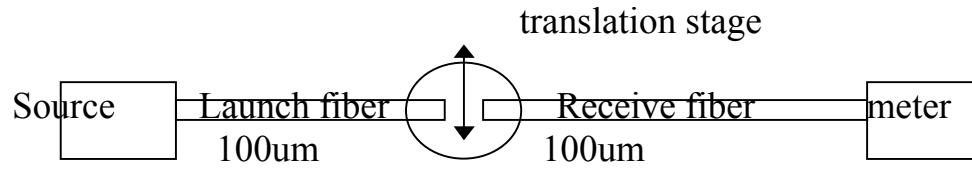

**Displace the two cores axially as shown in the sequence above**

100um launch fiber, 100um receive fiber

Rotation	Power in dBm	Power in mW
2°		
4°		
6°		
8°		
10°		
12°		
14°		
16°		
18°		
20°		
.		
.		
.		

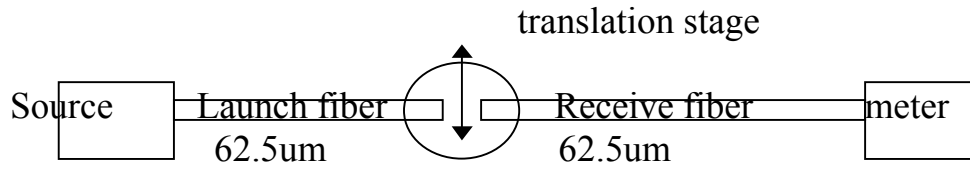

**Displace the two cores axially as shown in the sequence above**

62.5um launch fiber, 62.5um receive fiber

Rotation	Power in dBm	Power in mW
2°		
4°		
6°		
8°		
10°		
12°		
14°		
16°		
18°		
20°		
.		
.		
.		

Plot the data above using the angular rotation on the X axis and the power on the Y axis. Do that for the power in mW and in dBm. Observe the data, the rate at which the power drops as a function of the fiber core diameter.

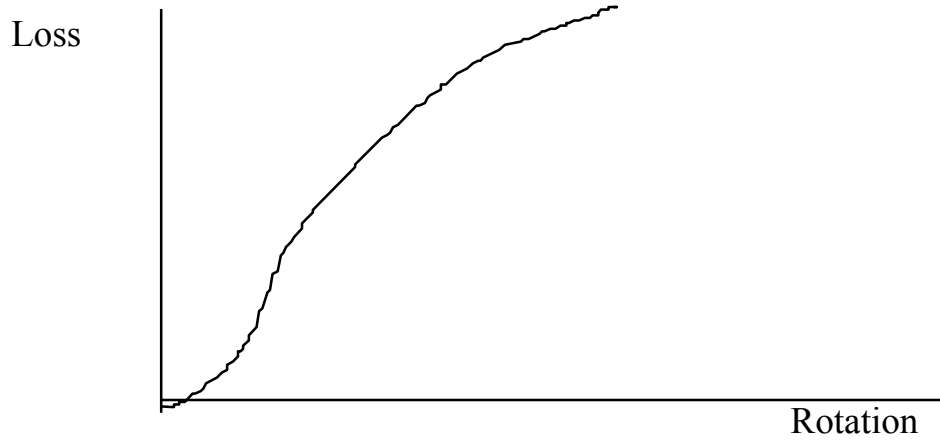

Your graphs should look something like this.

Do that for each of the fibers you have tested. Make a final comment on the most and least critical fiber when it comes to angular misalignment.

Plot the data twice, once using mW on the Y axis and another time using dBs on the Y axis. Compare the two plots and comment .

### 8- CALCULATION:

In this lab experiment, you are required to measure the power at the output of the receive fiber for every  $2^\circ$  increment depending on the size of the fiber you are using (that is if you are using more than one fiber). If you plot the values, you will have a graphical representation of the loss as a function of rotational separation. You can select points on your graph to predict the power loss for various rotational angles.

It is important to plot the data accurately to increase the accuracy of your readings from the graph.

Example calculation:

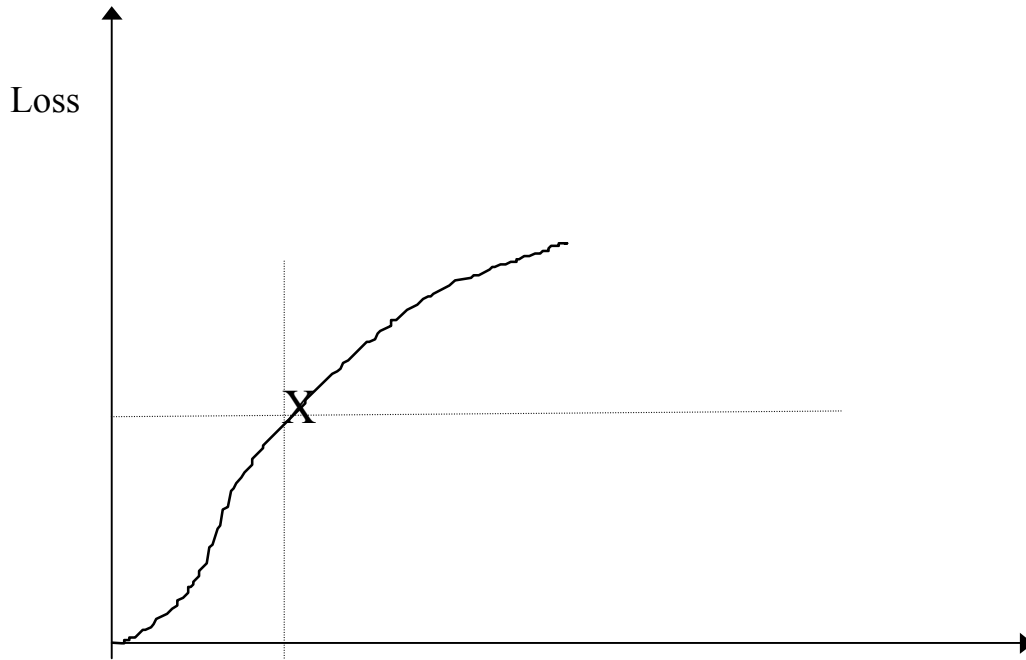

Using a calibrated scale on the graph paper, ( or from your computer) you can read the X and Y intercept of any point on the graph. Here, you have the ability to project the loss of optical power at any point on the graph. If your school have the resources, and if you have collected data for more than one fiber, you are required to generate a graph for each of the sets of data you have.

### 9- RESULTS:

Typically, the results of a laboratory exercise gives the student the opportunity to contrast the actual outcome to the anticipated outcome quantitatively. This does apply in this exercise unless you have access to the manufacturer's data sheet for this fiber.

Alternatively, if you have access to the equation to predict power loss as a function of separation, you should compare the calculated value to the values from the graph.

To calculate the theoretical power loss, you need to know the Numerical Aperture of the fiber. Alternatively, you can use the measured NA you obtained from a previous laboratory experiment.

### 10- DISCUSSION:

Student: Please write a short discussion. Describe, in your own words, how you would re-write this lab, if you had to. What you would change in it and why. What advise would you give to someone intending to do what you had just finished.

### 11- CONCLUSION:

Students: Please write a conclusion about this exercise. Contrast what was intended to what was accomplished. Explain the reason(s) for any differences between the two. In addition, offer recommendation(s) on how to make the outcome coincide with the objective. Do that so others doing this exercise will be able to make use of your recommendations and observations to achieve better match between the objective and conclusion.